

PB88-910411



# **NATIONAL TRANSPORTATION SAFETY BOARD**

WASHINGTON, D.C. 20594

## **AIRCRAFT ACCIDENT REPORT**

**CONTINENTAL AIRLINES, INC., FLIGHT 1713  
McDONNELL DOUGLAS DC-9-14, N626TX  
STAPLETON INTERNATIONAL AIRPORT  
DENVER, COLORADO  
NOVEMBER 15, 1987**

**NTSB/AAR-88/09**

**UNITED STATES GOVERNMENT**

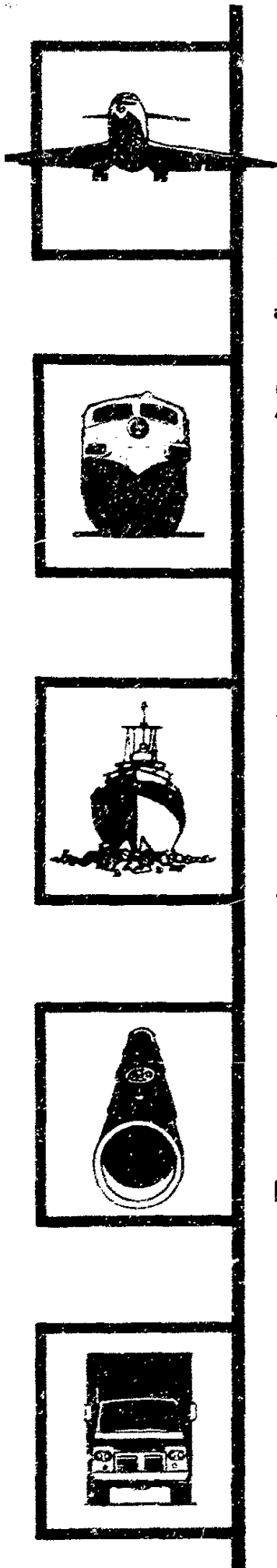

**TECHNICAL REPORT DOCUMENTATION PAGE**

1. Report No. NTSB/AAR-88/09		2. Government Accession No. PB88-910411		3. Recipient's Catalog No.	
4. Title and Subtitle Aircraft Accident Report--Continental Airlines, Inc., Flight 1713, McDonnell Douglas DC-9-14, N626TX, Stapleton International Airport, Denver, Colorado, November 15, 1987				5. Report Date September 27, 1988	
				6. Performing Organization Code	
7. Author(s)				8. Performing Organization Report No.	
9. Performing Organization Name and Address  National Transportation Safety Board Bureau of Accident Investigation Washington, D.C. 20594				10. Work Unit No. 4772A	
				11. Contract or Grant No.	
12. Sponsoring Agency Name and Address  NATIONAL TRANSPORTATION SAFETY BOARD Washington, D.C. 20594				13. Type of Report and Period Covered  Aircraft Accident Report November 15, 1987	
				14. Sponsoring Agency Code	
15. Supplementary Notes					
<p>16. Abstract: On November 15, 1987, Continental Airlines, Inc., flight 1713, a McDonnell Douglas DC-9-14, N626TX, was operating as a regularly scheduled, passenger-carrying flight between Denver, Colorado, and Boise, Idaho. The airplane was cleared to take off following a delay of approximately 27 minutes after deicing. The takeoff roll was uneventful, but following a rapid rotation, the airplane crashed off the right side of runway 35 left. Both pilots, 1 flight attendant, and 25 passengers sustained fatal injuries. Two flight attendants and 52 passengers survived.</p> <p>The National Transportation Safety Board determines that the probable cause of this accident was the captain's failure to have the airplane deiced a second time after a delay before takeoff that led to upper wing surface contamination and a loss of control during rapid takeoff rotation by the first officer. Contributing to the accident were the absence of regulatory or management controls governing operations by newly qualified flightcrew members and the confusion that existed between the flightcrew and air traffic controllers that led to the delay in departure.</p> <p>The safety issues discussed in the report include pilot training, aircraft deicing procedures, and wingtip vortex generation and lifespan.</p>					
17. Key Words:  icing; deice; Continental Airlines, Inc.; vortex; pairing				18. Distribution Statement This document is available to the public through the National Technical Information Service, Springfield, Virginia 22161	
19. Security Classification (of this report) UNCLASSIFIED		20. Security Classification (of this page) UNCLASSIFIED		21. No. of Pages 93	22. Price

## CONTENTS

	<b>EXECUTIVE SUMMARY</b> .....	v
1.	<b>FACTUAL INFORMATION</b>	
1.1	History of the Flight .....	1
1.2	Injuries to Persons .....	4
1.3	Damage to Airplane .....	4
1.4	Other Damage .....	4
1.5	Personnel Information .....	4
1.5.1	The Captain .....	4
1.5.2	The First Officer .....	5
1.6	Airplane Information .....	7
1.7	Meteorological Information .....	8
1.8	Aids to Navigation .....	9
1.9	Communications .....	9
1.10	Aerodrome Information .....	9
1.10.1	Continental Deicing Procedures .....	12
1.10.2	Denver Control Tower Procedures During Deicing .....	13
1.11	Flight Recorders .....	15
1.11.1	Cockpit Voice Recorder .....	15
1.11.2	Flight Data Recorder .....	15
1.12	Wreckage and Impact Information .....	16
1.13	Medical and Pathological Information .....	20
1.14	Fire .....	20
1.15	Survival Aspects .....	20
1.15.1	Interior Damage and Occupant Injuries .....	20
1.15.2	Crash/Fire/Rescue Activities .....	22
1.16	Tests and Research .....	23
1.16.1	Engine Teardowns .....	23
1.16.1.1	Left Engine .....	23
1.16.1.2	Right Engine .....	23
1.16.2	Airplane Systems Teardowns and Testing .....	23
1.16.2.1	Electrical System .....	23
1.16.2.2	Flight Control System .....	24
1.17	Additional Information .....	24
1.17.1	Preflight Activities of the Crew .....	24
1.17.2	FAA Flow Control Into Denver .....	25
1.17.3	Effects of Airframe Contamination on Airplane Performance .....	25
1.17.4.1	Anti-Ice Protection .....	27
1.17.5	Wingtip Vortices and Flight 1713 .....	27
2.	<b>ANALYSIS</b>	
2.1	General .....	28
2.2	Continental DC-9 Training .....	29
2.2.1	The First Officer's Initial Operating Experience .....	29
2.3	Airport Snow Removal .....	29
2.4	<i>Wingtip Vortices</i> .....	30
2.4.1	Wake Vortex Factor 1: Airplane Weight .....	30
2.4.2	Wake Vortex Factor 2: Vortex Generation Altitude .....	30
2.4.3	Wake Vortex Factor 3: Atmospheric Instability .....	31

2.4.4	Wake Vortex Factor 4: The Lack of a Vortex Encounter .....	31
2.5	Airplane Deicing and Subsequent Contamination .....	33
2.6	Aerodynamic Effects of Airframe Contamination and the Results of the Contamination on Flight 1713 .....	34
2.7	Airplane Maintenance and Certification .....	35
2.8	The First Officer's Actions During Rotation .....	36
2.9	The Captain's Actions .....	37
2.10	Crew Pairing .....	38
2.11	Sterile Cockpit Procedures .....	39
2.12	Continental's Preemployment Screening .....	39
2.13	The Role of the Clearance Delivery and Ground Controllers and Continental Flight 594 in the Takeoff Delay of Flight 1713 .....	39
2.14	FAA Flow Control Into Denver .....	40
2.15	Survivability .....	41
2.16	Crash/Fire/Rescue Activity .....	41
3.	<b>CONCLUSIONS</b>	
3.1	Findings .....	43
3.2	Probable Cause .....	44
4.	<b>RECOMMENDATIONS</b> .....	45
5.	<b>APPENDIXES</b>	
	Appendix A--Investigation and Hearing .....	47
	Appendix B--Personnel Information .....	48
	Appendix C--Cockpit Voice Recorder Transcript .....	49
	Appendix D--Flight Data Recorder Data .....	85
	Appendix E--FDR Altitude Traces for the Six Previous Flights .....	86
	Appendix F--CFR and Medical Concerns .....	87

## EXECUTIVE SUMMARY

On November 15, 1987, Continental Airlines, Inc., flight 1713, a McDonnell Douglas DC-9-14, N626TX, was operating as a regularly scheduled, passenger-carrying flight between Denver, Colorado, and Boise, Idaho. The airplane was cleared to take off following a delay of approximately 27 minutes after deicing. The takeoff roll was uneventful, but following a rapid rotation, the airplane crashed off the right side of runway 35 left. Both pilots, 1 flight attendant, and 25 passengers sustained fatal injuries. Two flight attendants and 52 passengers survived.

The National Transportation Safety Board determines that the probable cause of this accident was the captain's failure to have the airplane deiced a second time after a delay before takeoff that led to upper wing surface contamination and a loss of control during rapid takeoff rotation by the first officer. Contributing to the accident were the absence of regulatory or management controls governing operations by newly qualified flightcrew members and the confusion that existed between the flightcrew and air traffic controllers that led to the delay in departure.

The safety issues discussed in this report include:

- pilot training;
- aircraft deicing procedures; and
- wingtip vortex generation and lifespan.

Recommendations concerning these issues were addressed to the Federal Aviation Administration, the National Fire Protection Association, the American Association of Airport Executives, the Airport Operators Council International, and Continental Airlines, Inc.

# AIRCRAFT ACCIDENT REPORT

CONTINENTAL AIRLINES, INC.  
FLIGHT 1713  
McDONNELL DOUGLAS DC-9-14, N626TX  
STAPLETON INTERNATIONAL AIRPORT  
DENVER, COLORADO  
NOVEMBER 15, 1987



## 1. FACTUAL INFORMATION

### 1.1 History of the Flight

On November 15, 1987, Continental Airlines, Inc., (Continental) flight 1713, a McDonnell Douglas DC-9-14 registered in the United States as N626TX, was a regularly scheduled, but delayed, passenger-carrying flight between Denver, Colorado, and Boise, Idaho. The original departure time of 1225 was adjusted due to adverse weather conditions at Denver. The flight was to be the first of a 3-day sequence of flights for the captain and first officer. Continental flight 1713 was to be the beginning of the captain's third trip sequence as a DC-9 captain and the first officer's second trip sequence as a line first officer in the DC-9.

The captain commuted to Denver from San Diego, California, arriving at 1118, about 12 minutes before his scheduled "show time" of 1130. The first officer commuted to Denver from Houston, Texas, on the previous day.

Between 1200 and 1230, the captain signed a dispatch flight release for flight 1713. The captain indicated on the release that he was a "high minimums"<sup>1</sup> captain. The captain also asked for a weather update from the Continental weather clerk a short while later. While the crew was in the gate area of the terminal awaiting the arrival of the airplane, one of the flight attendants asked the captain who was going to make the landing at Denver on the return leg. The captain replied that he would be making the landing. The flight attendant later stated that she was concerned because she had heard that the weather was supposed to remain poor at Denver and she knew that the first officer was new to the company.

At 1303, the first officer contacted clearance delivery and received a routine clearance to Boise Airport; however, the flight did not request taxi clearance from air traffic control even though their path to the deice pad crossed a designated airplane movement area. Denver Tower is not equipped with Airport Surface Detection Equipment (ASDE) and visibility was about 2,000 feet. Consequently, air traffic control was unaware that flight 1713 had taxied from its gate. The flight then proceeded to the deice pad where it was deiced between snorkels 1 and 2 after the crew shut down the engines.

<sup>1</sup>Title 14 CFR 121.652 states, in part, that: "If the pilot in command of an airplane has not served 100 hours as pilot in command in operations under this part in the type of airplane he is operating, the MDA [minimum descent altitude] or DH [descent height] and visibility landing minimums in the certificate holder's operations specification . . . are increased by 100 feet and one-half mile (or the RVR [runway visual range] equivalent). The MDA or DH and visibility minimums need not be increased above those applicable to the airport when used as an alternate airport, but in no event may the landing minimums be less than 300 and 1."

The operator of a deicing truck that assisted in the deicing of flight 1713 stated that the trucks had been ordered to spray the tail surfaces of every airplane going through the deice pad. He characterized some accumulations of snow on airplanes as 1 inch, but he did not specifically remember the upper surface accumulation on flight 1713. He recalled an ice/slush buildup on the nose gear of the airplane, which he removed.

The cockpit voice recorder (CVR) indicated that the last sound of deicing spray hit the airplane at 1346:22. At 1347:30, one of the flightcrew members stated "Blast off," and at 1349:01, a flightcrew member called "Commence start."

Meanwhile, at 1346:58 Continental flight 594 called clearance delivery with a request to go to the deice pad. The clearance delivery controller told the flight to monitor ground control. At 1347:33, the ground controller told the flight to "taxi to the pad." Continental flight 594 stated that they were prevented from taxiing because they were blocked by another Continental airplane. The ground controller then told flight 594 to let him know when they could taxi, and they replied "Wilco." Several minutes later, the flightcrew stated that they were ready to taxi to the deice pad, and the controller replied "Continental 594, watch for two companies inbound to the deice, taxi to the north side of the runup 35 left." The flightcrew responded with "594." The crew, did not question the controller's instructions, and contrary to those instructions, taxied to the deice pad to be deiced.

At 1351:12 the crew of flight 1713 contacted clearance delivery for the second time with the radio call "... taxi from the ice pad." The clearance delivery controller acknowledged with the radio call "Continental 1713 monitor ground twenty-one nine." The clearance delivery controller later stated when he received this transmission he thought flight 1713 was still at its gate and was asking for clearance to the deice pad. He did not note that the captain used the word "from" in his radio transmission.

Several seconds later, the ground controller contacted flight 1713 with the radio call "Continental 1713 left side taxi to the pad give way to two companies on the south side of Delta goin' into there it's an Airbus and a ah MD-80." The crew initially responded with "Roger," but after some cockpit discussion about the intent of the instructions, requested clarification. The ground controller responded, "Yeah behind the Airbus. I think ah he's just got out of the alleyway now. They're goin' northbound."

At 1358:51, the captain called for the taxi checklist which was accomplished shortly afterward. The flightcrew taxied the airplane from the deice pad to the ramp area near the end of runway 35L where they awaited takeoff clearance. At that juncture, the order of flights on the north side of the runup area for runway 35L was as follows: Continental flight 1617, Continental flight 65, and Continental flight 1713. A short while later, Continental flight 875 taxied in behind flight 1713. The order of aircraft on the south side of the runup area at that time was as follows: United flight 227 and TWA flight 124.

At 1400:56, the local controller cleared Continental flight 1617 into position to hold. The CVR revealed that a crewmember of flight 1713 then said "We're next." This was not a radio transmission. Shortly afterward, the local controller attempted to contact Continental flight 594 to clear it onto the runway but received no response. At that time, flight 594 was still in the deice pad with engines and radios off. At 1405:14, Continental Flight 65 took off. Shortly afterward Continental 875 acknowledged a radio check from the tower controller. At 1405:53, the captain of flight 1713 then prompted the first officer to advise the tower controller that they were in the number one position on the north side.

Between 1402:46 and 1404:59, the flightcrew of flight 1713 mentioned a runway visual range call of 2,200 feet that they overheard on tower frequency and briefly discussed the captain's status as a "high minimums captain." They also stated that the flaps should be set to their final setting

because there was not "much slop between here and the end [of the runway]," and they mentioned that the adverse weather at Denver may remain for some time. At 1411:08 they talked about *running the engines up to a high power setting every 10 minutes*. No mention was made of airframe surface contamination after the completion of deicing on the CVR tape. Between 1408:23 and 1411:08, the captain and first officer engaged in nonpertinent social conversation.

At 1405:26, an arriving general aviation airplane, N706PC, reported that he was on the ground. The next arriving airplane in the landing stream was about 6 miles behind N706PC. At this point, flight 1713 was physically in the number one position and the crew was ready to take off.

At 1406, the first officer of flight 1713 called the tower controller but received no response. The tower controller then inquired if Continental 875 could get around a company MD-80, referring to what he thought was Continental flight 594; flight 875 responded "Affirmative." At 1408:07, the flightcrew of flight 594 contacted ground control for clearance to taxi from the deice pad to the end of the runway. Clearance was granted, and the flight taxied into the takeoff lineup shortly thereafter.

As flight 875 taxied around flight 1713 and onto the runway, the first officer on flight 1713 again called the tower and stated that they were number one for takeoff. At 1407, the controller inquired if Continental flight 594 was listening and if flight 1713 was an MD-80. Continental flight 594 again did not respond because it was not monitoring tower frequency. The crew of Continental flight 1713 then replied that they were a DC-9. The captain of flight 875 stated that about this time he observed the right side of flight 1713. He later stated that he could discern no visible contaminants on the airplane other than a 4- by 4-foot, square-shaped patch of snow or frost on the fuselage and that he based his takeoff decision on that observation. Flight 875 took off at 1412. Shortly afterward, Continental flight 1713, now correctly identified by the tower, was cleared onto the runway. At 1413, Continental flight 875 called the local controller and reported that "there was a little clutter on the runway."

At 1414:31, flight 1713 was cleared for takeoff. The winds were reported to be from 360° at 14 knots with a runway visual range (RVR) of 2,000 feet. The captain was making the cockpit callouts and was conducting the nonflying pilot duties. At 1414:51, increasing engine sounds were recorded on the CVR. At 1415:06.7, the captain reported that the power was set at 95 and 93 [N2 engine compressor revolutions per minute in percent]. At 1415:17.1, he announced 100 knots. He called "V1" at 1415:28.5, "rotate" at 1415:30.9, and "positive rate [of climb]" at 1415:36.5. Less than a second later, the sounds of nosewheel rotation stopped. At 1415:39.5, the sound of a compressor surge was heard, followed by an exclamation by a crewmember and three more engine compressor surges. The sound of initial impact with the ground was recorded at 1415:43.8. The flight data recorder (FDR) recorded a maximum airspeed of about 165 knots and a maximum G load of +1.4 during the flight. This information was recorded at 1415:39.5. The accident occurred during daylight hours at 39°46'28" North, 104°53'45" West.

A fuel-fed flash fire ignited somewhere in the left wing area shortly after the wing began to contact the ground during the impact sequence. A "fireball" associated with the flash fire was momentarily noted inside the cabin by several passengers. After the wreckage came to rest, several small residual fires that caused minor damage to airframe components were quickly extinguished by the first fire department units to arrive on scene. The captain, the first officer, 1 of 3 flight attendants, and 25 passengers died during the accident. Two flight attendants and 52 passengers survived.



## 1.2 Injuries to Persons

<u>Injuries</u>	<u>Crew</u>	<u>Passengers</u>	<u>Others</u>	<u>Total</u>
Fatal	3	25	0	28
Serious	1	27	0	28
Minor/None	<u>1</u>	<u>25</u>	<u>0</u>	<u>26</u>
Totals	5	77	0	82

## 1.3 Damage to Airplane

The airplane was destroyed by impact forces and small fires following impact. The estimated value of the airplane was \$4.5 million.

## 1.4 Other Damage

None.

## 1.5 Personnel Information

### 1.5.1 The Captain

The captain was hired by Continental on January 6, 1969. He held airline transport pilot certificate No. 1898373, with type ratings for the CE-500 and DC-9, along with airplane multiengine land and commercial privileges for airplane single-engine land, issued April 3, 1987. He received his initial type rating in the DC-9 on April 3, 1987, and his last proficiency check in the DC-9 simulator on October 30, 1987. On his type rating check ride of April 3, the requirement to demonstrate proficiency in recovering from approach to stalls in the takeoff, clean, and landing configurations was waived by the lead Federal Aviation Administration (FAA) flight examiner on board at the time. The approach to stall maneuvers were waived because allotted time in the simulator expired before they could be accomplished. Two extra instrument approaches were flown by the captain because one of the FAA flight examiners mismanipulated the simulator visibility control during the ride. According to Federal Aviation Regulation (FAR) 14 CFR Part 121, Appendix F, "Proficiency Check Requirements," only two out of these three approach to stall configuration maneuvers are waivable. On his proficiency check in the simulator on October 30, the captain demonstrated average performance in recovering from an approach to stall in the takeoff configuration. On this check ride, approach to stalls in the landing and clean configurations were waived by the Continental check airman. His last recurrent training was completed on October 16, 1987. His most recent FAA first class medical certificate was issued on October 8, 1987, with no limitations. He also held flight engineer certificate No 1912062 with ratings for turbojet powered airplane, issued March 3, 1969. He had accumulated approximately 12,125 total flying hours, of which 6,069 hours were pilot time including 3,111 hours as first officer in the B-727 and 133 hours as first officer in the DC-9. All of the captain's DC-9 first officer time was flown after March 13, 1987. He had a total of 33 hours as a DC-9 captain.

The captain's duties with Continental began as a second officer in the B-727 and continued from his date of hire until June 1977 when he became a first officer in that airplane. His service in the B-727 was interrupted during May through August 1973, when he served as second officer on McDonnell Douglas DC-10s. Following this interruption, he again served as first officer in the B-727 until December 1982, when he reverted to second officer status due to company furloughs. He took part in a labor strike against Continental between October 1, 1983, and July 31, 1986, when he returned to duty as a Continental second officer in the B-727. He completed DC-9 ground school training on March 13, 1987.

The captain completed the entire required Continental DC-9 training program with no notable problems. During his initial operating experience (IOE), a period of initial line flying with a Continental instructor pilot which culminated in an FAA observed check ride, he encountered one area of difficulty. The captain did not allow enough spacing between the preceding airplane on a final approach for landing and was forced to execute a missed approach. The instructor then decided to extend his IOE flying time by one trip sequence. However, the instructor did not consider this an "unsatisfactory" performance but thought that the captain would feel more comfortable after several more flight hours with an instructor. The FAA observer on board at the time stated that he considered the entire flight acceptable and would have approved the captain for line flying at that time. One more trip sequence of IOE was then performed by the captain, ending in a successful FAA observed check ride.

According to his instructor, on simulator periods 3, 4, 5, and 6, the captain received specific instruction on aircraft icing protection systems and aircraft deicing during those periods. Unique deicing procedures at Stapleton also were taught during these simulator sessions. According to his seventh simulator period instructor, the captain gave a "thorough and professional" briefing on airframe and engine icing and the effects of icing on takeoffs. His instructor during IOE also recalled discussing deicing with the captain as required by Continental company policy. The Continental operations manual states "A repeat visual inspection of aircraft surfaces is required if snow or freezing precipitation is present and 20 minutes have passed since the last inspection or de-icing." The captain was scheduled to attend the company cockpit resource management program but had not done so by the time of the accident.

## 1.5.2 The First Officer

The first officer was hired by Continental on July 20, 1987. He held airline transport pilot certificate No. 463331081, with ratings for BE-300, BE-1900, airplane multiengine land, and commercial privileges for airplane single-engine land, issued November 4, 1986. He completed his initial DC-9 training with a proficiency check on September 14, 1987. His most recent FAA first-class medical certificate was issued on June 11, 1987, with no limitations. He also held flight instructor certificate No. 463331081CFI, issued on September 8, 1986. He had accumulated approximately 3,186 total flying hours, of which 36 hours, the extent of his turbojet experience, were in the DC-9.

The Safety Board's investigation of the training and performance history of the first officer examined the 5-year period before his employment by Continental. The first officer received a total of 4.8 hours of initial multiengine flight instruction before a check ride administered by an FAA-designated flight examiner on December 7, 1983. The check ride lasted 0.5 hour with no instrument time logged and one landing accomplished. On February 17, 1984, the FAA revoked the flight examiner's examination authority because the examiner had issued a flying certificate to another pilot without conducting the required flight test items. FAA records revealed that the examiner had been under investigation for "short checking" since May 1983.

In March 1985, the first officer's employment as a pilot with an on-demand Part 135 commercial operator was terminated because he "failed [a] Part 135 (PIC IFR Multi) check after 30 hours of training," according to the former president of the company. The logbook of the FAA examiner who administered the checkride indicated that the first officer "failed to properly intercept 7.0 DME arc at GLS [Galveston, Texas]; went below minimums on app[roach] at stepdown; failed to feather SE [single-engine] (unsat)." The company's chief flight instructor stated that the first officer experienced habitual difficulties in single-engine procedures and directional control and that he made little progress in training because he repeated the same mistakes. He also stated that the first officer had a chronic problem of stepping on the wrong rudder and becoming disoriented, and he described the first officer as tense and unable to cope with deviations from the routine. He recalled

that the first officer had failed the checkride on three occasions before his employment was terminated.

On March 25, 1985, the first officer was hired by a Part 135 regional airline as a first officer in Beech BE-1900 scheduled commuter operations. During upgrade training in May 1986, instructor comments in company training records documented that the first officer was "weak on memory items on V1 cut, had to miss the first two ILS's" and "approaches are going to need a lot of work, became disoriented in holding, concentrate exclusively on inst. approaches and procedures, continue training." On May 31, 1986, he failed to successfully complete an Airline Transport Pilot/BE-1900 type rating flight examination administered by an FAA examiner. On that flight, he passed a designated holding fix at cruise speed before realizing his mistake and also did not perform an ILS approach to specified tolerances, according to the examiner. The first officer underwent additional training and on June 6, 1986, he successfully completed that check ride and was upgraded to captain.

The FAA requires air carriers to conduct security checks of pilot applicants before employment because they have unescorted access to airport security areas. These checks must include, at a minimum, reference and prior employment histories for verification of employment during the preceding 5 years. There is no requirement to verify previous flight experience or to determine an applicant's FAA accident/incident history or enforcement history, previous employer's pilot training and performance records, and criminal and driver histories. Although employment verification for the preceding 5-year period is mandated, commercial operators are not required to maintain pilot records for that length of time.

The corporate security section at Continental commissioned a background check on the first officer through a private company. According to this background check, which was dated July 28, 1987, the first officer was employed by an on-demand Part 135 commercial operator between February 1984 and March 1985. This operator was the only previous employer mentioned in the report. In answer to the question in the report "Did the subject leave on his or her own accord?" the answer was "Yes." In answer to the question "Would the subject be eligible for re-hire?" the answer was "Yes." Lastly, according to the background check, the quality of the first officer's work was described as "Very good."

The first officer completed Continental's DC-9 ground school on August 11, 1987, and two cockpit procedures trainer (CPT) periods on August 26, 1987. As part of his ground school training, he attended the company's 2-day cockpit resource management program. He then entered into a series of instructed visual simulator periods. Following the second period, the instructor's written comments were: "SCAN! Need to review (procedures) and profiles." On the third period he was described as "... Better, but scan still needs work, and a little jerky on flight controls." After the fourth period, the instructor commented, "Scan still needs work. Pitch control jerky, altitude control when pressure is on is somewhat sloppy. Knowledge of (maneuvers) is good." On the fifth period, administered on September 2, the comments indicated general improvement; "Scan is better. Still a bit jerky on pitch! [the first officer] seems to have caught up with airplane today." The comments from his sixth period on September 8, with a different instructor indicated "Scan is a real problem, completely lost control of airplane with engine out and at 2,000! Went into 45°-60° angle of bank, lost 1,500! Had to be arrested by (instructor). Altitude and airspeed control generally way out of limits. Some basic procedures still require review." The first officer's unsatisfactory progress in the sixth period necessitated a repeat of the simulator session which was accomplished with the same instructor and only one student. The first officer received 3 hours of training in the available 4-hour block. The instructor did not grade the flight "normal progress," but made the following comments:

1. Needs to review limitations and profiles.
2. Falls behind in planning, also not sure of what to do next--may lack experience.

3. Scan was a problem during first half of three hour period but improved toward the end.
4. [The first officer] was advised on areas requiring improvement thoroughly debriefed--recommended for P.C. [proficiency check].

The first officer completed the seventh period in the simulator on September 11 with a third instructor who commented, "Nice job! No problems." He then completed the proficiency check in the airplane on September 14, 1987, with another instructor who graded his performance "average" and offered no amplifying comments.

The first officer began DC-9 IOE on October 2, 1987, under the provisions of 14 CFR 121.434 which states, in part:

A second-in-command pilot must perform the duties of a second-in-command under the supervision of a check pilot or observe the performance of those duties from the flight deck.

All of the first officer's IOE took place while he was performing the duties of a second-in-command pilot in accordance with Continental's policy. The check airman commented that his takeoff rotation was somewhat slow and identified descent/arrival planning as needing improvement, but he was satisfied with the overall performance. Following the final trip of the IOE, on October 8, the check airman wrote, "No significant problem areas noted. Excellent attitude, should make a fine employee. Released to line operations."

The first officer received training on aircraft icing protection systems and deicing during the prebriefings of simulator periods 2 and 4, according to his instructor on those simulator periods. He also received similar training during his IOE according to his IOE instructor.

The first officer had not been on duty for 24 days before the accident because he was in a reserve pilot status. Continental's chief pilot at Denver had "bought" the accident trip sequence from a more senior pilot who had been scheduled for the trip and had scheduled the first officer for the trip sequence to help him maintain proficiency.

## 1.6 Airplane Information

N625TX, a McDonnell Douglas DC-9-14, serial No. 45726 (fuselage No. 36) was owned and operated by Continental. The airplane was originally delivered to Air Canada in 1966. It was leased to Texas International Airlines in 1968 and sold to Continental in 1982. The airplane had accrued 52,424 hours and 61,888 cycles at the time of the accident.

The airplane was equipped with two Pratt and Whitney JT8D-7B engines. At the time of the accident, the left engine had operated 35,274 hours and 40,710 cycles, and the right engine had operated 42,184 hours and 54,759 cycles.

The airplane's center of gravity at takeoff was calculated to have been 24 percent of mean aerodynamic chord (MAC). The planned airplane takeoff gross weight was 86,800 pounds. Both the center of gravity and gross weight were within operating limits.

N626TX was maintained in accordance with Continental's FAA-approved interval-based maintenance and inspection program. All maintenance and inspection functions required by this program were recorded as having been performed within their specified time intervals.

A review of the flight logs for the airplane from September 15, 1987, until the date of the accident showed that 89 flight/maintenance discrepancies were recorded during that time period. All discrepancies, except two, were signed off as having corrective actions accomplished. These discrepancies were an inoperative cockpit light and an inoperative center fuel tank quantity gauge. The fuel quantity gauge was not repaired at the time of the accident. However, the airplane was considered airworthy because it was being flown with the center fuel tank intentionally containing only residual fuel.

Engine condition monitoring program documents showed that both engines were operating within their allowable limits in the 60 days preceding the accident. Test cell data for both engines showed that the measured operational parameters were within their specified normal operating limits.

A review of the FAA's service difficulty reports associated with the airplane did not reveal any significant problems. All of the applicable airworthiness directives were completed within their specified limits. All of the applicable service bulletins for the airplane also were accomplished.

The airplane configuration consisted of three seats in the cockpit including the unoccupied jump seat; 83 passenger seats; an aft-facing, two-person flight attendant jump seat on the forward bulkhead, and a forward-facing, two-person flight attendant jump seat on the aft bulkhead. Due to the particular cabin seating configuration on this DC-9, there were no seat rows numbered 1, 4, 13, 17, 18, 19, or 20.

## 1.7 Meteorological Information

Surface weather observations taken by the National Weather Service (NWS) at Stapleton before and after the accident are as follows:

Time--1351 m.s.t.; type--surface aviation; ceiling--indefinite 500 feet obscured; visibility--1/2 mile; weather--moderate snow and fog; temperature--28° F.; dew point--27° F.; wind--030° at 10 knots, gusting to 17 knots; altimeter--29.92 inches; remarks--Runway 35R visual range 1,200 feet.

Time--1445; type--surface aviation; ceiling--indefinite 300 feet obscured; visibility--3/8 mile; weather--moderate snow and fog; wind--030° at 10 knots, gusting to 18 knots; altimeter--29.92 inches; remarks: Runway 35R visual range 600 feet (airplane mishap).

NWS personnel, stated that they did not take a special weather observation closer to the actual time of the accident because they were not notified of the accident until about 1445.

At the time of the accident, the NWS was describing the precipitation at Stapleton as moderate snow.<sup>2</sup> Based upon the reflectivity from a CP-2 doppler radar array located 22 miles north-northwest of the airport, the heaviest snowfall rate occurred between 1310 and 1420, reaching a maximum snowfall rate about 1350. During the approximate 27 minutes before the beginning of flight 1713's takeoff roll, approximately 0.036 inch of water equivalent, or 0.292 inch of snow, fell on the airport. The ratio of 8.1 inches of snow to 1 inch of water, was derived from actual measured snow depths compared to actual rain gauge moisture measurements between 1045 and 1644. The normal range of ratios of snow depth to liquid water equivalent is from 6.7 to 14.3 inches per inch, the former being wet snow and the latter dry. The snowfall at the time of the accident was wet snow.

<sup>2</sup>Snowfall which reduces the visibility to less than 5/8 of a statute mile but not less than 5/16 of a statute mile.

The runway visual range (RVR) values of runway 35R in the approximate 1/2 hour before the accident ranged between 1,000 and 1,800 feet. The NWS only records RVR values for runway 35R at Denver. The RVR values given to flights just before takeoff are for the runway the flights are using. The recorded RVR values around the time of the accident for the right runway were as follows:

<u>Time</u>	<u>RVR (feet)</u>
1411	1,000
1413	1,000
1414	1,200
1416	1,000
1417	800

The winds recorded from the low level wind shear alert system (LLWAS) were provided by the FAA for 1410:04 to 1419:44. Observations were taken from each sensor at approximately 7-second intervals. (See figures 1 and 2.)

According to flight documents found in the wreckage, the printed weather information available to the crew included an amended Denver terminal forecast issued by the NWS Forecast Office at Denver and valid after 0700. The portion of the forecast valid at the time of the accident forecast a 500-foot overcast ceiling, visibility 2 miles in light snow. Winds were forecast to be 020° at 15 knots, gusting to 25 knots. Occasionally the ceiling was forecast to be 500 feet broken, 1,200 feet overcast with a visibility of 5 miles in light snow showers. In addition, an hourly surface aviation weather report observation taken at 1150 and valid at 1200 was available, along with winds aloft information.

There were no NWS Airman's Meteorological Information (AIRMET) reports, Significant Meteorological Information (SIGMET) reports, or convective SIGMETs in effect for the Denver local area at the time of this accident.

## 1.8 Aids to Navigation

There were no reported difficulties with navigational aids.

## 1.9 Communications

No equipment-related communications difficulties were reported among air traffic control agencies or between these agencies and the aircrews involved in this accident.

## 1.10 Aerodrome Information

Stapleton International Airport is owned and operated by the City and County of Denver, Colorado. It is fully certificated under 14 CFR Part 139. The airport is comprised of two primary runway complexes of three runways each; the east-west runway complex is on the south side of the airport and the north-south runway complex is on the north side. The primary jet runways are 17R-35L, 17L-35R (on the north side) and 8R-26L, 8L-26R (on the south side.) The more typical arrangement using the north-south runways for departures and the east-west runways for arrivals (or vice versa) was not in effect at the time of the accident. Due to the weather conditions on November 15, only runway 35L was being used for takeoffs and only runway 35R was being used for landings.

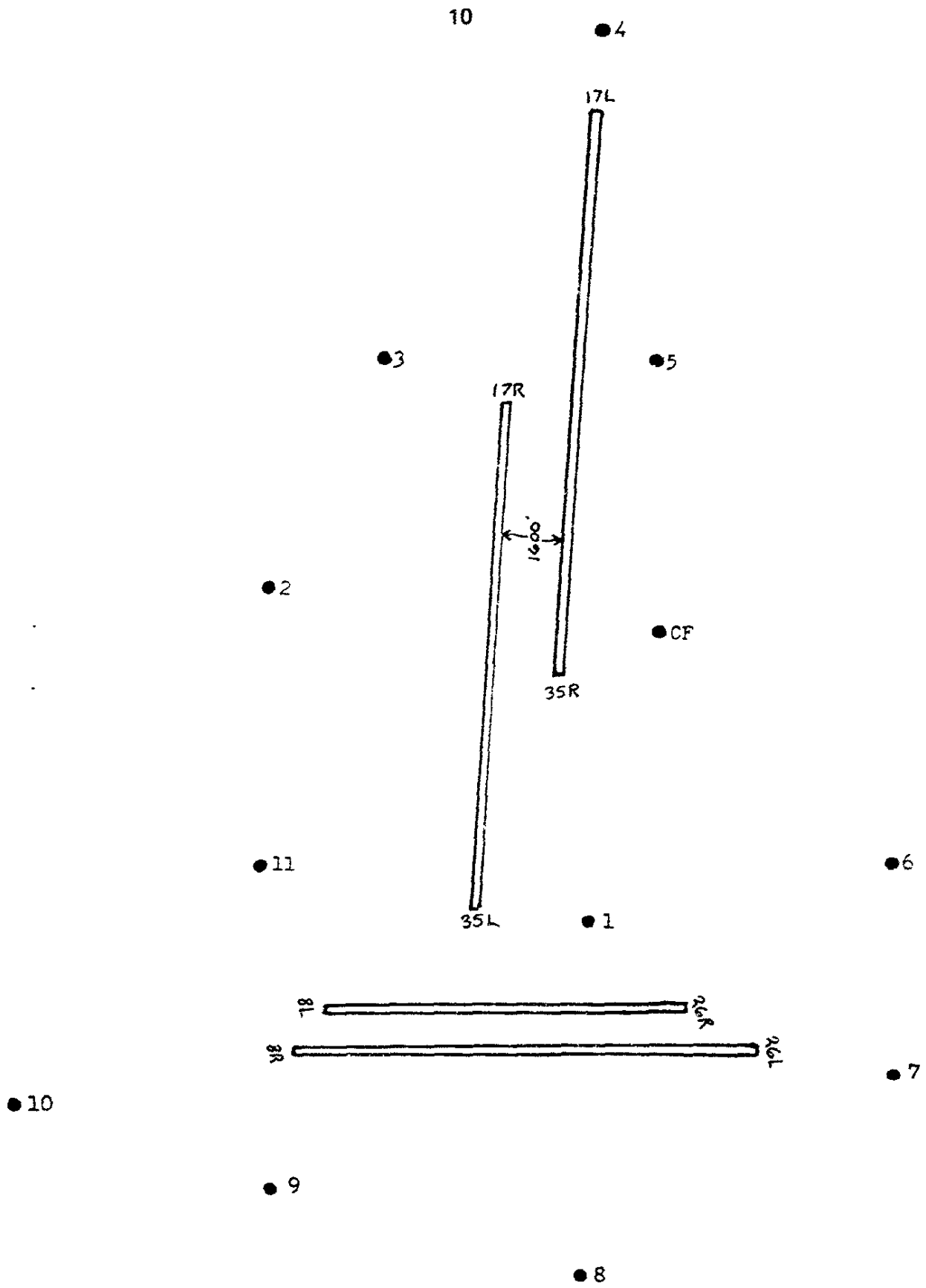

Figure 1.—Wind sensor locations.

Wind Averages from the Low Level Wind Shear Alert System (LLWAS) 1410:04 to 1419:44

LLWAS SENSOR	AVERAGE WIND DIRECTION (degrees magnetic)	AVERAGE WIND SPEED (knots)	MAXIMUM WIND SPEED (knots)	MINIMUM WIND SPEED (knots)	STANDARD DEVIATION WIND DIRECTION (degrees)	STANDARD DEVIATION WIND SPEED (knots)
Center Field	6.7	15.1	21.0	10.1	4.7	2.1
Gust (Center Field)	N/A	17.8	24.3	N/A	N/A	2.5
#1	22.1	15.5	20.6	10.1	4.8	2.1
#2	20.8	15.5	19.0	12.8	3.1	1.4
#3	13.7	16.1	22.5	12.0	4.5	2.1
#4	14.2	14.7	18.8	9.7	3.5	1.9
#5	16.4	15.1	19.8	12.0	3.9	1.9
#6	7.5	3.9	7.2	1.9	11.3	1.0
#7	12.3	8.0	14.4	4.1	9.4	2.3
#8	4.3	9.9	15.3	5.4	9.0	2.3
#9	25.3	14.4	18.6	10.1	4.2	2.5
#10	39.2	9.5	14.9	6.4	9.0	1.9
#11	23.3	14.4	18.6	9.9	3.0	1.9

Figure 2.--Wind sensor observations.

Note: Only the average gust speed and maximum gust speed are recorded on the center field LLWAS sensor.



Stapleton International Airport has no ASDE. This radar equipment is used to assist tower controllers in monitoring the location and movement of aircraft and vehicles on runways and taxiways during conditions of reduced visibility. When ASDE was installed at selected airports in the 1960's, Stapleton did not qualify based on the criteria of at least 180,000 itinerant and 100,000 scheduled air carrier operations. Later, Stapleton's traffic count increased and, in 1975, it was ranked No. 10 to receive an ASDE. At that time, however, there were no units available and no funding was appropriated to purchase them. In fiscal year 1985, funding was approved for 17 new ASDE-3 systems and, in fiscal year 1986, an additional 13 systems were funded. Stapleton is scheduled to receive the ASDE-3 system between May and August 1989.

Runway 35L is 11,550 feet long and 150 feet wide. It is constructed of concrete with transverse grooving the full length and width. Forty-foot wide concrete shoulders are located on each side of the runway, which is equipped with high-intensity runway lights (set at its highest setting at the time of the accident) and a simplified short approach lighting system with runway alignment indicator lights. Runways 35L and 35R are approximately 1,600 feet apart, as measured from their centerlines. The threshold of runway 35R is displaced about 5,700 feet farther north than the threshold of runway 35L.

Snow removal activity on runway 35L began about 0400 on the day of the accident. A notice to airmen issued at 0425 stated that the runway was "...chemically treated full length and width. Covered with up to 1/16 inch wet snow. Braking action fair (.35) by Tapley." The runway was plowed about 0600. A notice to airmen issued at 0620 stated, "Runway 35L plowed and sanded full length and width. Covered with up to 1/8 inch snow. Braking action poor (.23) by Tapley." No airport snow removal activity occurred after this plowing. The airport operations (AOM) manager reported that by 0835 traffic on the runway had increased, that the runway was showing some exposed pavement, and that some pilots were reporting "good" braking action. At 0930, the AOM and the Continental snow committee representative toured the runway and noted that "quite a bit" of bare concrete along the centerline was showing. The AOM stated that conditions were essentially the same when he observed the runway at 1350. He stated that at 1417, when he was notified of the accident, he observed painted runway markings with patches of snow on the runway centerline as he approached the accident site.

### 1.10.1 Continental Deicing Procedures

Continental maintains ramp control towers on both the C and D concourses, primarily for gate assignments. The C concourse tower controls flow of Continental airplanes to the de-ice pad. The supervisor in the D concourse tower stated that on the day of the accident most airplanes had some snow on their upper surfaces and that N626TX had accumulated about 1/2 inch of snow on the top of its wings before pushback from the passenger gate.

The fixed airplane deicing facility at Denver is owned and operated by Continental. Although it had been used several times the previous spring, the day of the accident was the first time the facility had been used in the winter of 1987. Once an airplane arrived at the deice facility, movement into a specific pad was controlled by an assigned maintenance supervisor who was responsible for the overall activity. On the day of the accident, the assistant supervisor of maintenance for Continental at Denver manually controlled the glycol/water mix facility for the deicing snorkels due to a malfunction in the automatic mixing feature of the equipment. He stated that in addition to the four snorkels, four trucks were deicing the empennage of the airplanes. He commented that deicing completion capability was greater than the airport departure rate and that he believed airplanes were waiting too long after deicing before takeoff. He stated that there should have been some coordination with the tower to reduce or eliminate the delays.

The assistant supervisor of maintenance stated that the deicing fluid mix tank holds 9,000 gallons and was heated to between 170° and 180° F, with 150° being the minimum acceptable

temperature. The tank was refilled when the fluid level reached about 1/3 full. The mix ratio was capable of being computer controlled; however, on the day of the accident, the assistant supervisor of maintenance manually controlled the mix of the deice solution to achieve about a 20° spread between ambient air temperature and the freezing temperature of the mix. On November 15, the freezing temperature of the glycol/water mix was averaging between 6° and 10° F. Testing of the deicing fluid following the accident revealed that it consisted of about 38 percent glycol and 62 percent water. The assistant supervisor of maintenance also stated that while the deice trucks have heaters for the solution, they generally are not needed because the preheated fluid does not cool down before the truck tank is refilled.

Continental aircrew deicing procedures in effect at the time of the accident were provided on page 10-7A of the Jeppesen manual. (See figure 3.)

### 1.10.2 Denver Control Tower Procedures During Deicing

Runway 35L departures were being worked by the Local Control 1 (LC1) controller and runway 35R arrivals were being worked by the Local Control 2 (LC2) controller. Due to the distance between runways 35L and 35R, simultaneous IFR takeoff and landing operations were not authorized. Simultaneous ILS approaches require runways that are at least 4,300 feet apart.

FAA procedures state that the LC1 controller must provide separation for successive departures and, if there are any arrivals on runway 35R, he must provide separation between the arrivals on 35R and the departures on 35L. This is basically the same as a one-runway operation. The LC1 controller was able to apply separation on the day of the accident by observing the radar display in the tower cab and by monitoring airplane transmissions on the LC2 frequency.

The passing of information from controller to controller in the tower is accomplished by means of flight progress strips with flight data printed on the strip. The location of the strip in the tower conveys information about the location of the airplane on the airport. Normally, when the Continental deicing procedure is in use, a strip representing a Continental airplane passes through four flight progress strip racks ("bays"), representing proposed or current positions of the airplane.

The bays are as follows: CLEARANCE, DEICE, GROUND, LOCAL.

The normal sequence of events is:

1. When ready to taxi from the gate to the deice pad, the flight advises the clearance delivery controller who then places the strip in the ground control bay while instructing the flight to monitor ground control.
2. The ground controller issues taxi clearance to the de-ice pad. When assured (by observation or report) that the airplane is at the de-ice pad, the ground controller places the strip in the deice bay.
3. When ready to taxi from the deice pad to the runway, the flight again advises the clearance delivery controller who takes the strip from the de-ice bay and passes it to ground control while telling the airplane to monitor ground control.
4. The ground controller issues taxi clearance to the departure runway. When assured that the airplane is nearing the runway, he places the strip in the local bay, telling the flight to monitor the tower (local control) frequency. The strip remains there until the local controller calls the flight and clears it for takeoff.

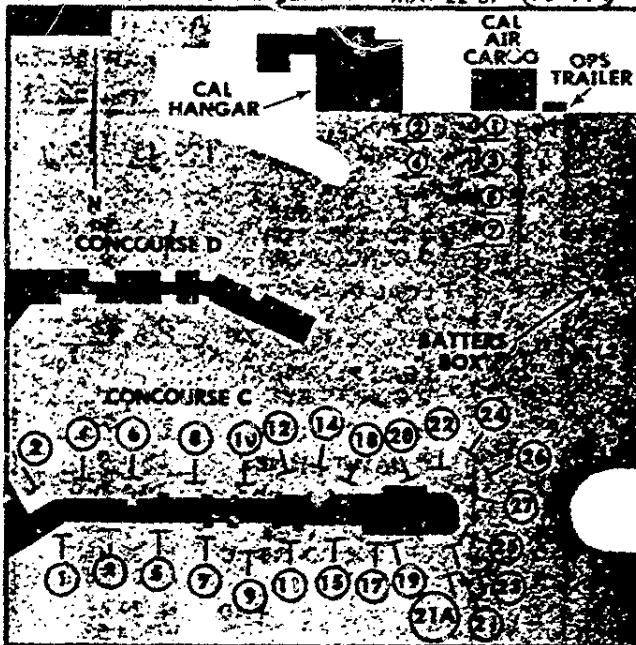

This procedure was developed in an effort to de-ice aircraft as near takeoff time as possible.

Time required for this procedure is approximately 30 minutes (40 minutes DC-10). Time includes 10 minutes to depart gate and taxi to pad and 20 to 30 minutes for de-icing.

When gate hold procedures are in effect Clearance Delivery or Gate Hold issues taxi times. Aircraft are expected to be ready to taxi for takeoff at that time. Therefore, it may be necessary to request a later taxi time to allow for de-icing.

**1. IF GATE HOLD PROCEDURES ARE IN EFFECT:**

Inform Ramp Control of your expected taxi time so that they can schedule de-ice of your aircraft. Continue to monitor both Ramp Control and Clearance Delivery (or Gate Hold as appropriate) so that changes can be coordinated. i.e.: New taxi time would require new de-icing time. Delays on de-ice pad might require new taxi time.

**IF GATE HOLD PROCEDURES NOT IN EFFECT:**

Contact Ramp Control for coordination of de-ice and for pushback clearance.

2. When cleared by Ramp Control to start engines and taxi, taxi to East end of Concourse C and contact Clearance Delivery requesting clearance to taxi to the pad. Clearance Delivery will hand you off to Ground Control.
3. On arrival at the pad ground personnel will direct aircraft onto pads 1,2,3,4,5, and 7 via the East edge of the ramp to park on a Westerly heading. Wide body aircraft will use only Pads 2 and 4. De-icing for aircraft on the D concourse is located at the old Frontier hangar. All MD-80/DC-9 aircraft will be inspected by maintenance after de-icing.
4. Use aircraft side number, not flight number, when communicating with de-ice pad ground personnel.
5. Shut down all engines and leave APU running. When notified that spraying is about to begin, shut off all air conditioning packs and close APU bleed valves. **PACKS MUST BE OFF TO AVOID FUMES AND SMOKE IN CABIN DUE TO INGESTION OF DE-ICE FLUID.**
6. Inform Ramp Control when de-icing of your aircraft is complete and start engines.
7. When ready to taxi from de-icing pad contact Clearance Delivery and they will hand you off to Ground Control.

**ACARS PROCEDURE**

1. DC-10, MD-80, 727, 737, A300:
  - a. During initialization, if planning to go to the pad to be de-iced, insert "ICE" in destination.
  - b. On arrival at pad, select MISC 16, enter current GMT and send.
  - c. After de-icing is completed and ready to leave the pad, select MISC 17, enter current GMT and send. Re-initialize ACARS with your actual destination.
  - d. If delay is encountered while on the de-ice pad, send DELAY message using MISC Code 11.
2. DC-9:
  - a. During initialization, if planning to go to the pad to be de-iced, insert "ICE" in destination.
  - b. On arrival at pad, select MISC 16 and enter. Insert current GMT using ETA button and amount of fuel on board. Enter and send.
  - c. After de-icing is completed and ready to leave the pad, select MISC 17 and enter. Insert current GMT using ETA button and amount of fuel on board. Enter and send. Re-initialize ACARS with your actual destination.

Figure 3.--Aircraft deicing procedures in effect on November 15, 1987.

## 1.11 Flight Recorders

### 1.11.1 Cockpit Voice Recorder

The airplane was equipped with a Fairchild model A-100 CVR. All channels on the CVR were operating. The voices of the crew, the sounds produced by the engines, and the sounds produced by the nosewheel were examined. The recording was of good quality, beginning at 1343:46 while the airplane was in the process of being deiced and ending approximately 1 second after the first sound of airframe impact with the ground at 14:5:43.8 (See appendix C.)

Compressor section (N2) sounds from the engines were identified on the tape from 1414:49 until the end of the recording. During this time, the N2 engine noise indicated an increase in engine speed above idle setting, which continued to increase to a nominal speed of 93 percent (consistent with a normal takeoff power setting) at 1415:03, and it remained at that setting until the end of the recording. The only other time an engine was advanced above idle was at 1410:00, when one engine was advanced slowly to approximately 83 percent N2 speed for about 1 minute.

The Safety Board identified sounds on the CVR tape as similar to compressor stalls or surges at 1415:39.5, 1415:40.2, 1415:42.2, and 1415:43.0. These sounds were compared with sounds identified as compressor stalls or surges on a past DC-9-10 series accident CVR recording. The sound of a stall warning stick shaker was present in the comparison CVR recording but was not present in flight 1713's recording.

Sounds that were attributed to increasing nose wheel noise began on the CVR at 1415:23.5 and ended at 1415:38.8. The rotational frequency of the nose wheel was converted to a ground speed. It revealed that the ground speed rose from 106 knots (at the start of the noise) to a maximum of 142 knots (at 1415:30.5).

### 1.11.2 Flight Data Recorder

The Fairchild model 5424 foil-type FDR was removed from the wreckage intact. For an unknown reason, the foil was not advancing through the recording device at the expected data point separation rate of .0009 inch per data point during the accident sequence. (See appendix D.) The readout of the parameters reflects timing corrections to compensate for the anomaly.) Also, for an unknown reason, the FDR foil medium had stopped moving for an undetermined amount of time between the previous landing at Denver and the takeoff roll. Foil movement began again during the takeoff roll, however. "Zero time" for FDR parameter readouts begins, therefore, when the foil begins to move again. All FDR parameters concerning flight 1713 were examined. Also, the altitude traces on the foil for the previous six flights were incorporated into the investigation.

McDonnell Douglas engineering personnel stated that the DC-9 indicated altitude trace, as that of other airplanes, exhibits an "altitude dip" on the FDR foil while the airplane is on the ground and in the initial stages of rotation for takeoff. The altitude dip, which indicates an altitude lower than the actual runway elevation, results from air pressure deviations that occur near the static pressure ports. The air pressure deviations are generated by disturbed airflow that results from the pitched-up attitude and ground interaction. McDonnell Douglas personnel stated that the normal indicated altitude dip on initial rotation for the DC-9-10 series airplane is approximately 50 feet below field elevation.

Also, McDonnell Douglas personnel provided data that define the magnitude of the altitude dip relative to the pitch attitude during the rotation maneuver. The data were derived from a series of flight tests and had been corrected to the FDR static pressure source. The following information is valid only when the airplane's main landing gear is still on the ground during initial rotation:

<u>Pitch Attitude (degrees)</u>	<u>Altitude Dip (feet) (sea level)</u>	<u>Altitude Dip (feet) (5,300')</u>
0	0	0
4	-31	-40
8	-63	-73
12	-85	-100

The FDR recorded a dip in the indicated altitude trace upon initial rotation on the accident flight. The accident flight indicated altitude trace dipped down to about 120 feet below field elevation, which corresponded to a pitch attitude of about 14°. This was reached about 7.5 seconds after the captain called "Rotate." The FDR indicated 30 to 60 feet altitude dips for the six previous flights of N626TX. In addition, the slope of the trace from flight 1713 is about twice what it was on the six previous flights. (See appendix E.)

### 1.12 Wreckage and Impact Information

The main wreckage was located off the right side of runway 35L. The impact path began at 8,244 feet and extended to 9,312 feet from the takeoff threshold. The terrain sloped down from the side of the runway at a 2 percent grade for approximately 400 feet, then rose at a 10 percent grade for an increase in elevation of 20 feet.

Three major ground scars were found at the accident site. The first ground scar began 8,244 feet down and 114 feet to the right of the runway 35L centerline. The 214-foot scar angled away from the runway approximately 20° and then turned slightly back toward the runway. The left wingtip landing light lens retaining ring was located 8,257 feet down and 130 feet to the right of the runway centerline. The red glass left navigation light lens also was found in this area. Left wing debris was found in a line between this area and the second ground scar, a crater 11 feet by 11 feet by 9 inches. Examination of the dirt in the crater revealed pieces of glass identified as the outer glass panel of the left cockpit "eyebrow" window. A third major ground scar contained green glass lens material. Other debris in the area of the third crater consisted of various airplane components, including pieces of cabin interior, overhead compartment fragments, and passenger luggage.

The nearly intact empennage/tail cone section of the airplane was located approximately 250 feet down from the third scar. It was inverted and aligned on a magnetic heading of 234°. The empennage was coated with soot but showed no signs of thermal damage. The left horizontal stabilizer tip and left elevator tip were missing. Fragments from these components were located earlier along the wreckage path, south of the empennage.

The fuselage and right wing were located approximately 200 feet down from the empennage. The forward portion of the fuselage, which had split at fuselage station 446, was resting on its left side. Longerons 1R through 15R were intact but severely bent and distorted. This was the only structure connecting the forward fuselage to the rear fuselage. The left side of the forward fuselage was badly damaged. Much of the exterior skin and underlying structure was torn away and found along the wreckage path. The right side of the fuselage was distorted and dented in several areas near the forward baggage door. The aft portion of the fuselage was aligned with the forward half of the fuselage and resting inverted. The section of fuselage just aft of the break was collapsed to within inches of the cabin floor. The portion of the fuselage adjacent to the engines was collapsed to the level where the forward part of the engine was resting on the ground. The right wing remained attached in its proximate correct position. (See figures 4 and 5.)

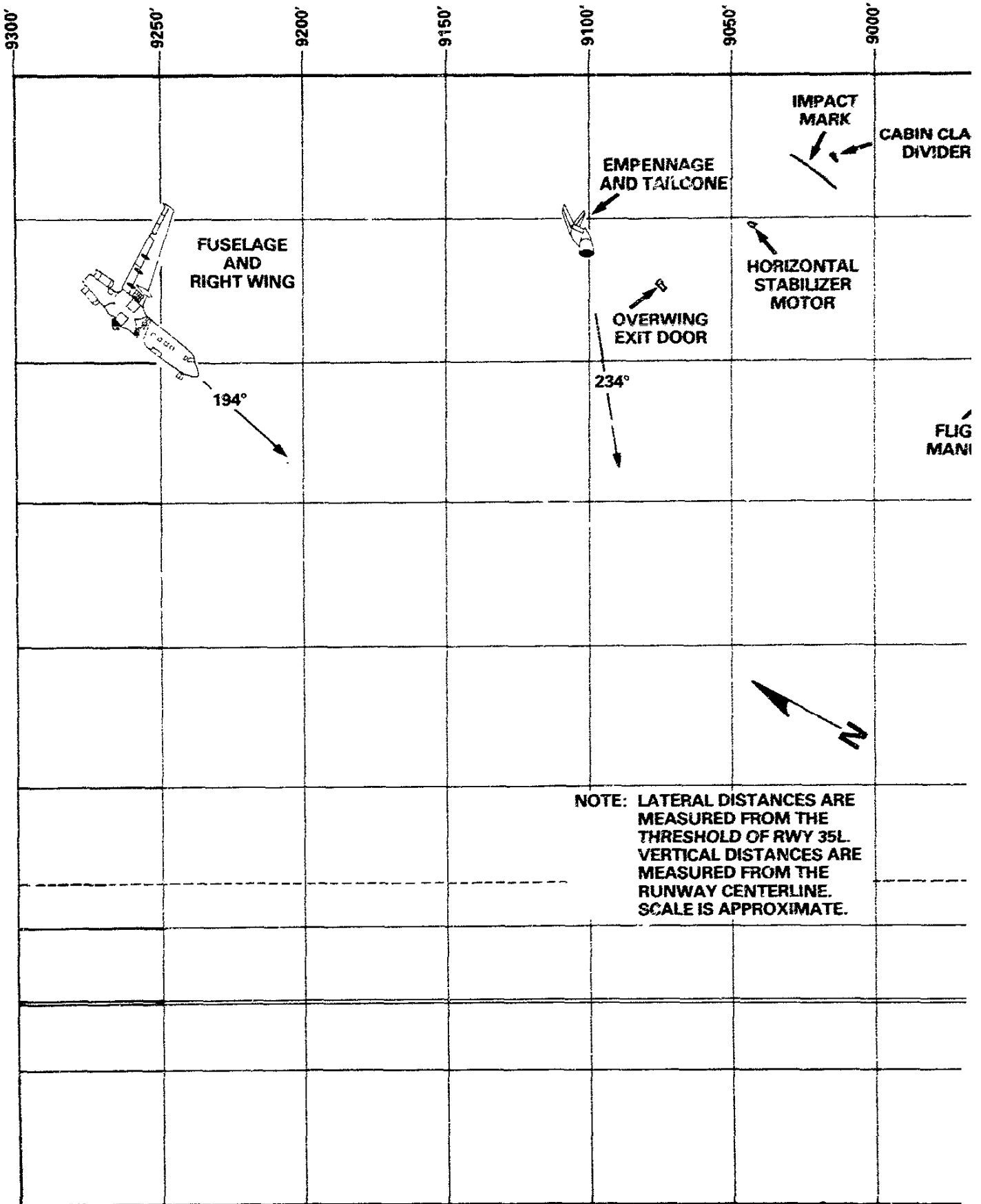

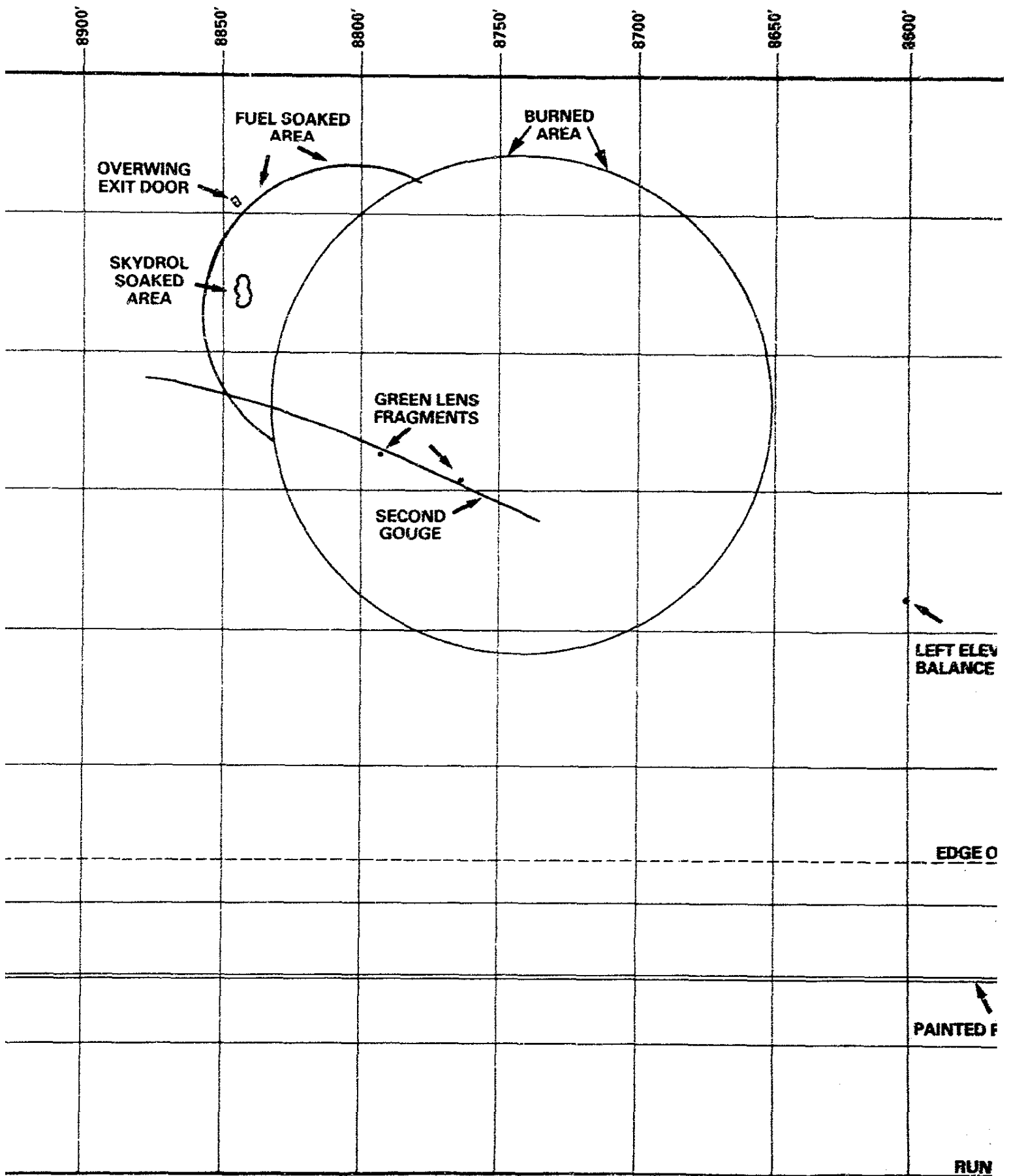
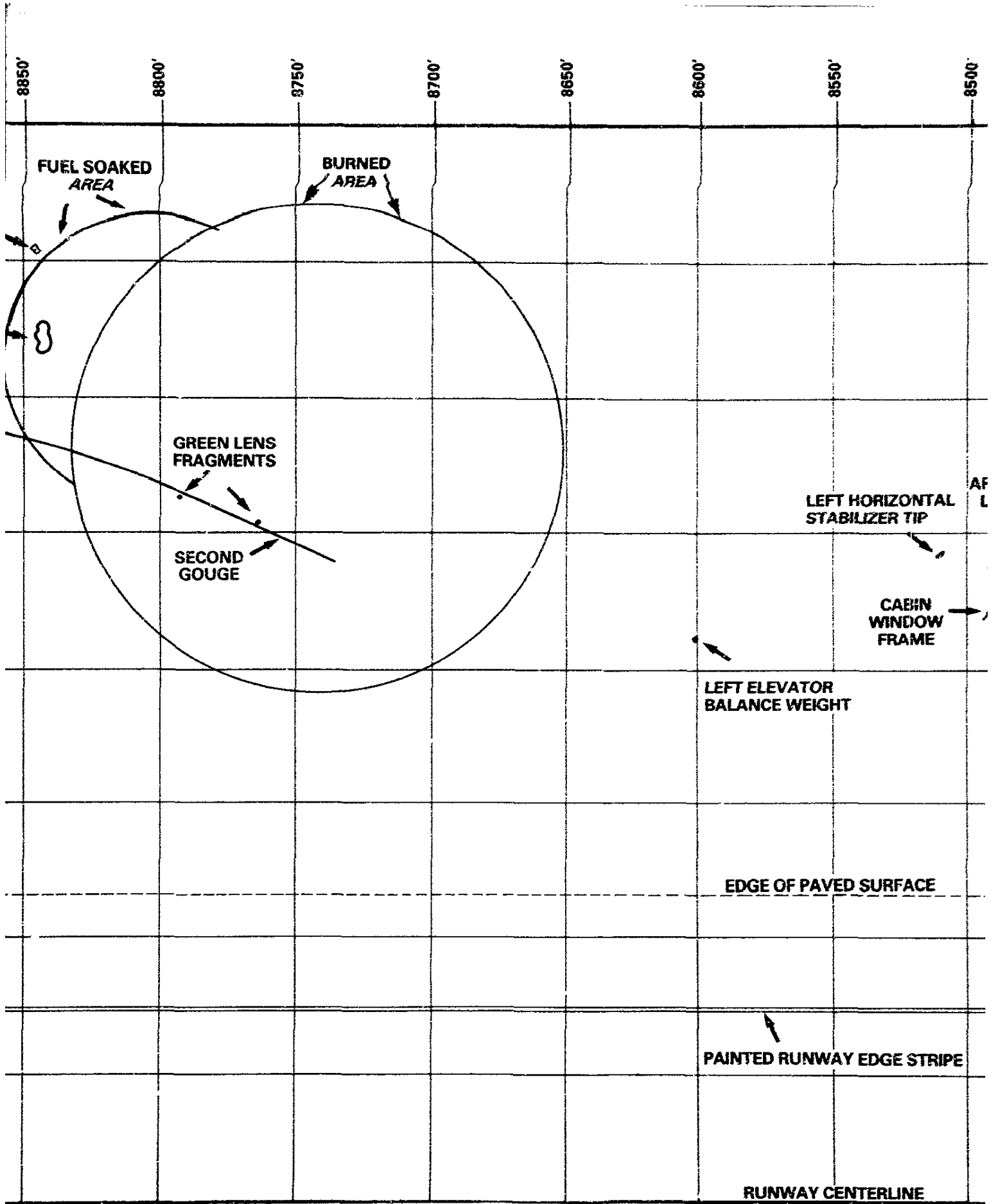
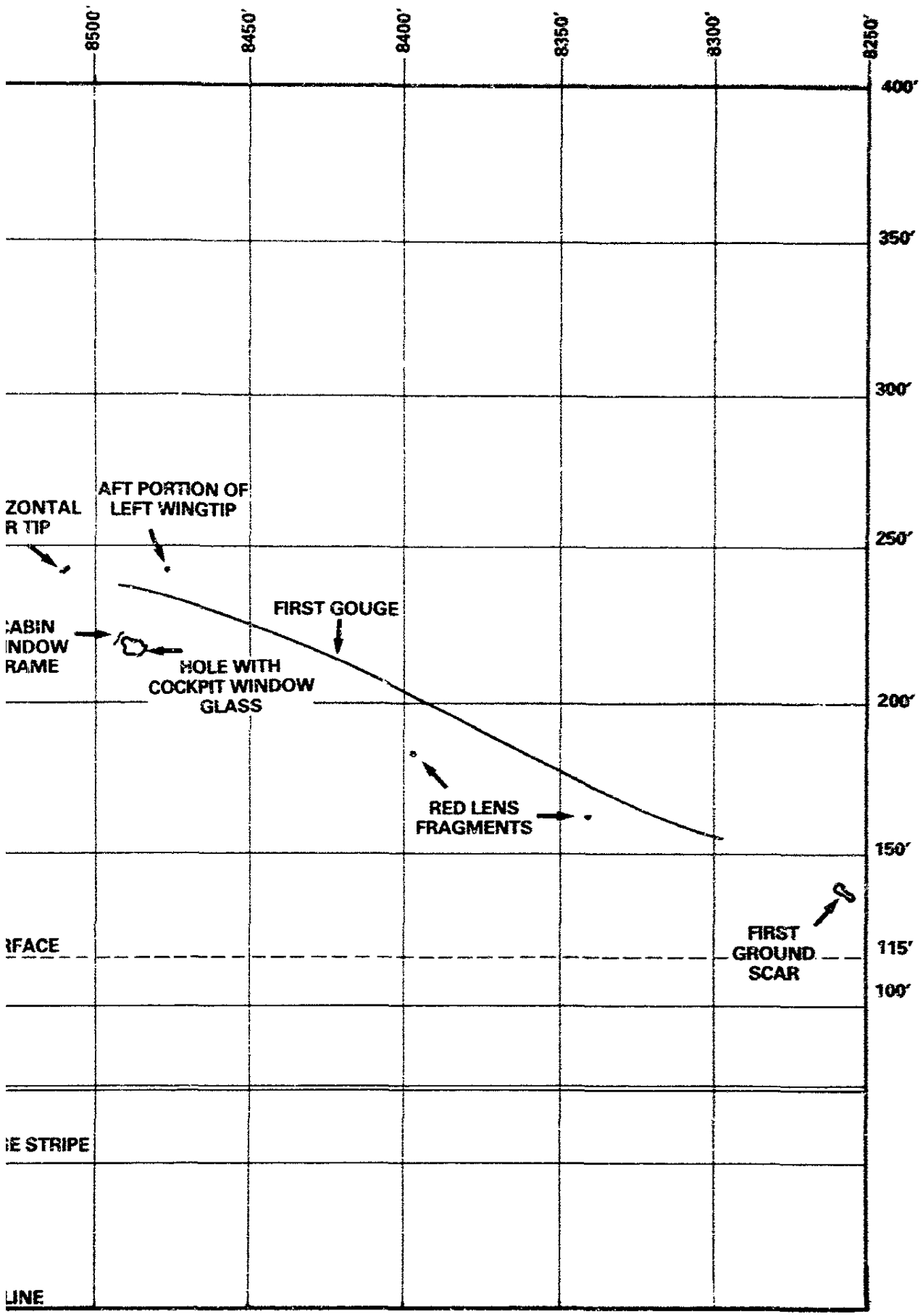

Figure 4. -- Wreckage diagram at accident site.



reckage diagram at accident site.





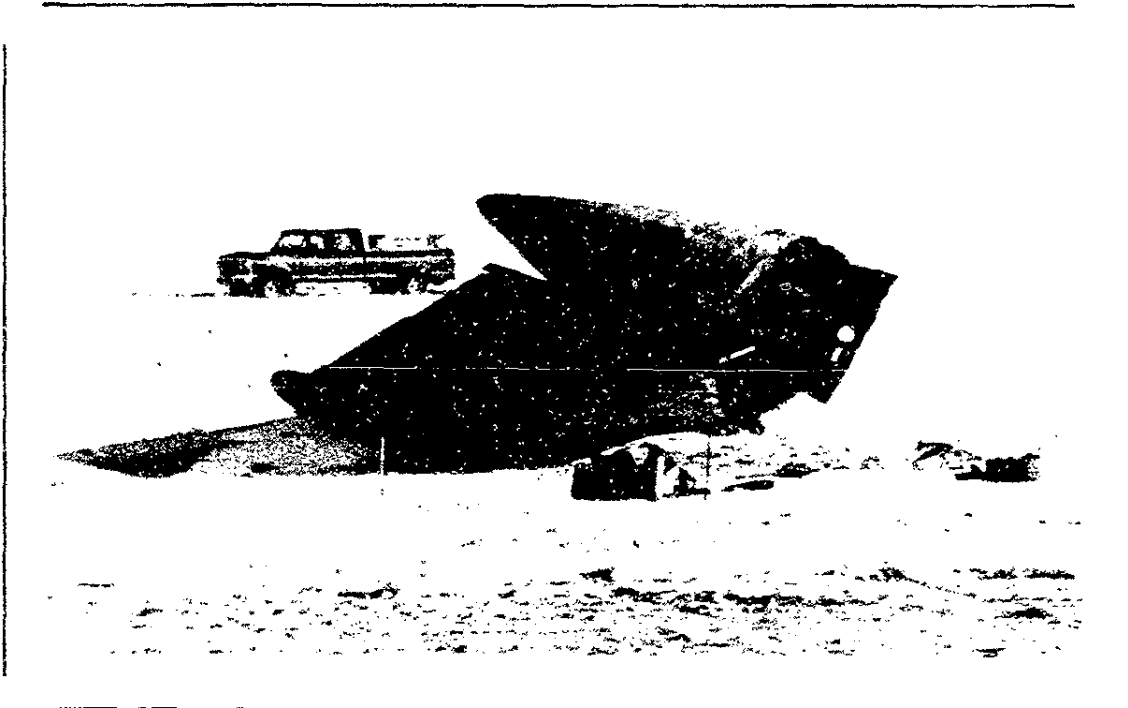

Figure 5.--Wreckage from flight 1713.

### 1.13 Medical and Pathological Information

No evidence of adverse medical histories or chronic or acute ailments for either pilot was discovered during the course of the investigation. According to friends and relatives, both were in good health at the time of the accident. Also, the general life habits and the specific activities of the pilots during the 3 days before the accident were routine.

Postmortem examinations were performed by the City and County of Denver's Coroner's Office. The autopsies revealed that 11 passengers (including an infant), the captain, the first officer, and 1 flight attendant died of multiple blunt force traumatic impact injuries; 5 passengers died of head injuries secondary to blunt trauma, and 9 passengers died of mechanical asphyxia. The Center for Human Toxicology, University of Utah, examined toxicological samples from all of the deceased and from one flight attendant who was hospitalized. No drugs (including alcohol) were detected in any of the samples taken from crewmembers, and no alcohol was detected in the passenger samples.

The 54 passengers and 2 flight attendants who survived the accident either escaped from the fuselage or were extricated within 4 hours after impact. Two passengers died after being transported to the hospital. The injuries to the survivors ranged from minor burns, lacerations, and contusions to serious spinal fractures and multiple internal injuries. Ten surviving passengers suffered first and/or second degree burns.

### 1.14 Fire

Several surviving passengers saw a fireball inside the fuselage during the impact sequence. Also, several residual fires were evident after the fuselage and intact wing came to rest. These were quickly extinguished by firefighters and caused only minor damage to the airframe.

### 1.15 Survival Aspects

#### 1.15.1 Interior Damage and Occupant Injuries

There was extensive damage to the forward left side of the airplane. The fuselage was missing on the left side from aft of the boarding door to about station 466. No one in a window seat in rows 2-9 on the left side survived. Cabin dividers, overhead compartments, and passenger seats were ejected during the impact and were found along the wreckage path. Some survivors in this section were thrown from the airplane while still belted in their seats and other survivors (including a passenger in seat 8E who was asleep and whose seatbelt was not fastened) remained in the fuselage. Several survivors in the forward cabin escaped through breaks in the fuselage while other passengers in this section required extrication. A 6-month old infant who was in his mother's lap in seat 5C died of multiple blunt trauma injuries and his mother survived with serious injuries. (Refer to figure 6 for distribution of injuries.)

Rows 10-15 were inverted and in an area of extreme compression. All occupants in this area required extrication. All survivors in this area had serious injuries and eight of the nine passengers who died of traumatic asphyxia were seated in this section.

Rows 15 aft were also inverted and the fuselage was compressed to within inches of the floor at row 15. There was progressively less fuselage compression toward the rear of the airplane. With the exception of the passenger in 22E who received a serious injury, all of the injuries to passengers in the last three rows were minor. The only occupant who was not injured was a 6-week-old, in-lap infant held by her father in seat 24E. Two flight attendants were seated on the aft jumpseat: one sustained a serious injury, the other minor injuries. Some passengers in the aft cabin were able to evacuate after the tailcone exit hatch was opened while others required extrication.

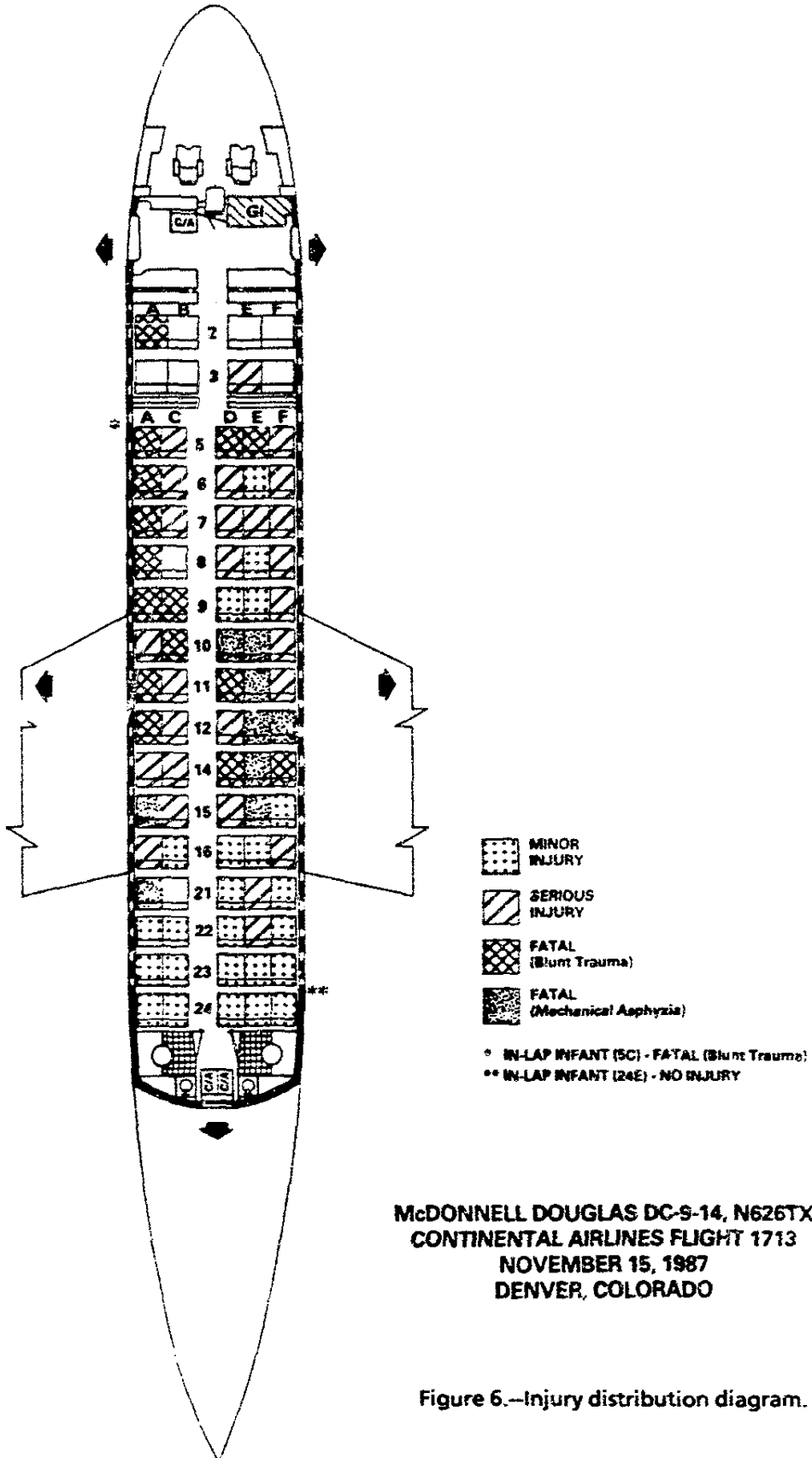

The only emergency equipment used by the flight attendants were portable flashlights located next to the aft jumpseat. The flashlights were passed to passengers who were trapped in the aft cabin during the rescue effort.

### 1.15.2 Crash/Fire/Rescue Activities

Both Stapleton Airport crash/fire/rescue (CFR) stations 1 and 2 were notified of the accident by the airport control tower at 1416. Both stations responded to the scene within several minutes with 5 CFR vehicles and 12 firefighters. According to CFR personnel, it was snowing hard at the time. At 1421, the first alarm was sounded for additional firefighting units from the City and County of Denver. A second alarm was sounded at 1433 and a third at 1500. Numerous structural firefighting and rescue units also responded from the City and County of Denver, Aurora, Sable-Altura, Thornton, and Glendale Fire Departments. After the firefighters extinguished several individual localized fires (1 to 1 1/2 feet high) located at the root area of the left wing, rescue activities quickly centered around three areas of the wreckage. Other individuals, including medical personnel and about 15 Continental workers arrived on the accident site later.

Passengers who escaped through breaks in the fuselage were found walking outside the airplane. These passengers and passengers who escaped through the tailcone exit were transported by bus away from the accident scene.

In the area of the aft tailcone exit, impact damage and debris delayed their evacuation 7 to 10 minutes. During the impact sequence, the aft right lavatory collapsed inward and portions of the lavatory structure blocked the removal of the tailcone exit hatch from the inside. Some debris was removed by the flight attendants with the assistance of passengers. Contributing to the delay was the fact that outside rescuers were hampered by limited visibility around the hatch area. The only instruction printed on the outside of the hatch was the word "Pull" on a placard near the hatch release handle. The hatch was then upside down because the fuselage was inverted.

Simultaneous rescue efforts also took place around the left wing root area of the missing left wing where 18 to 20 passengers were trapped. Rescue personnel worked about 2 1/2 hours to remove 6 to 8 survivors from this section of the airplane.

Rescue work also occurred around the wing root area of the right wing. Two passengers were extricated from this area alive. Four deceased individuals were found under the fuselage near the wing root after the fuselage was lifted off the ground. Rescue work to free trapped survivors in this area was hampered by shifting portions of the structure as structural members were cut by rescue workers. Because the right wing was still full of fuel, a high degree of danger existed from a possible outbreak of fire while rescuers cut away airplane structure to gain access to trapped passengers. As a result, extreme caution was necessary. At one point wooden cribbing was placed under the intact right wing to prevent it from settling downward. Eventually, a forklift was used to support the right wing.

Several areas of concern regarding CFR and medical response were noted during the investigation. These areas included, but were not limited to, a deficiency concerning communications, the proper type and amount of tools and equipment on hand at the time of the accident, triage equipment, and the level of rescue worker training. (See appendix F.)

## 1.16 Tests and Research

### 1.16.1 Engine Teardowns

Both engines were removed from the fuselage and shipped for disassembly to the engine manufacturer at East Hartford, Connecticut. The rotor systems and bearings of both engines maintained their operational centerlines and fore-and-aft alignment during the accident sequence. Various engine bearing supports, the engine bearings, and the bearing carbon seals of both engines were intact and not visibly damaged.

None of the compressor or turbine blade airfoils and compressor or turbine stator vanes of either engine had any indications of transverse fractures. Fuel samples retrieved from the airplane revealed no significant contaminants.

#### 1.16.1.1 Left Engine

All significant damage to the left engine, with the exception of one type of compressor damage, could be attributed to the ingestion of hard objects associated with the disintegration of the airplane during the impact sequence. There was no evidence of internal fire damage. The compressor damage consisted of impact marks on the trailing edges of the second stage compressor stator vanes that corresponded to the leading edges of the third stage compressor blades. The maximum depth of the marks was equivalent to a forward deflection of the third stage compressor blades of 1.2 inches. The third stage compressor stator vanes also exhibited impact marks that corresponded to the leading edges of the fourth stage compressor airfoils. These marks were equivalent to a forward deflection of the fourth stage compressor blades of 0.95 inch. The trailing edges of the fifth stage compressor stator vanes showed evidence of contact by the leading edge tips of the sixth stage compressor blades. These marks were equivalent to a forward blade deflection of about 0.44 inch. Associated with this damage was a large amount of metal splatter on the domes of all the combustion chambers and in the turbine section of this engine.

#### 1.16.1.2 Right Engine

All significant damage to the right engine could be attributed to the ingestion of hard objects associated with the disintegration of the airplane during the impact sequence. There was no evidence of internal fire damage.

### 1.16.2 Airplane Systems Teardowns and Testing

Detailed examination of the airplane's systems, their respective components, functions, and fault-indicating systems revealed no preimpact failures or malfunctions. Each system was found to be configured in a manner that was consistent for the takeoff and initial phase of flight. All of the damage to components and the few irregularities noted during functional testing of the components was attributed to damage sustained during the impact sequence.

#### 1.16.2.1 Electrical System

All of the electrical system panel switches and indicators, with one exception, were positioned correctly for the takeoff and initial phase of flight. The Emergency Power switch was found in the ON position. The Emergency Power In Use light bulb filament did not exhibit any evidence of stretch, however. In addition, the Emergency Power in Use and the Emergency Inverter circuit breakers were found in the open positions. The overhead panel in which the switch was mounted was displaced about 1/2 inch downward and to the right during impact, with the nose of the switch knob showing damage in the area where it had contacted the switch panel.

Both the captain's and the first officer's red "STALL" lights contained light bulbs with filaments that were found to be stretched upon examination following the accident. The original engineering order for the stall warning system called for these lights to be amber and overprinted with the letters "STALL WARN," rather than "STALL." In addition, the engineering order called for a "Stall Comparator Failure" light on the annunciator panel. This light was not present on the annunciator panel of N626TX. The "Stall Indicator Failure" light bulb on the annunciator panel of the aircraft contained a filament that was not stretched.

The right engine fire handle was in the deployed position with the handle rotated to the No. 2 bottle discharge position. Examination of the airplane fire protection system revealed that the bottles were still charged and that none of the fire detection loop lights exhibited filament stretch. The fire detection loops were tested successfully for continuity and resistance. The fire warning bell was not heard on the CVR tape.

### 1.16.2.2 Flight Control System

All of the flight control surfaces were present, though fragmented, in the wreckage. The major pieces included the flap with inboard and outboard hydraulic actuators and position transmitter, the inboard ground spoiler panel, two flight spoiler panels (inboard and outboard) and their respective actuators and torsion bars, the aileron with its control and trim tabs, drive and bus sectors, and the trim jackscrew.

The right wing, which remained attached to the fuselage center section, was complete. All of the flight control surfaces were attached and their respective control cables were in place and properly secured.

The tail section flight control surfaces remained attached to the empennage structure, which exhibited minor damage. The rudder and tab were intact and moved freely. Examination revealed that the tail interior components were present, intact, and mounted in their correct positions. The stabilizer jackscrew extension measurement indicated that it was set at 3.3° airplane nose up. The rudder limiter hook mechanism appeared to have been in the appropriate unrestricted mode at the time of the accident.

Flight control cable continuity could not be absolutely confirmed. Six flight control cables had separated in at least two locations along their lengths, and it was impossible to confirm which loose pieces of cable were originally attached to which flight control cables. In all cases, however, sufficient lengths of cable of the correct diameter were located within the wreckage to add up to the total length of cable necessary to complete an entire flight control system. All breaks in all cables were attributed to either mechanical instantaneous overload, to mechanical cutting that occurred during the breakup of the airplane, or to mechanical cutting during the rescue operation.

## 1.17 Additional Information

### 1.17.1 Preflight Activities of the Crew

The flightcrew's activities began in the Continental operations offices and were routine with two exceptions. First, neither the captain nor the first officer initialed the Read and Initial Book before the flight. The Read and Initial Book contained various bulletins and letters which clarified or emphasized operational procedures and policies. Nothing in this book pertained to the subsequent takeoff.

Although the captain signed a dispatch flight release and indicated that he was a "high minimums" captain, he did not communicate this to the dispatcher per company operations manual policy. In this case, the existing weather at Denver was below the captain's landing minimums,

which required incorporation of a takeoff alternate airport on the flight release. The dispatcher later stated that at least two airports were available as alternates, but no alternates or fuel for alternates were annotated on the flight release. The dispatcher also stated that if he had known that the captain was a "high minimums" captain, he would have notified the Denver Continental duty director. The duty director, in consultation with a Continental crew coordinator, would then make a decision as to the replacement of the captain due to low weather conditions. The dispatcher went on to say that replacement of a captain would have been the "exception, rather than the rule" in circumstances such as this.

### 1.17.2 FAA Flow Control Into Denver

Denver tower personnel stated that immediately before the accident, there were no traffic flow restrictions for departing airplanes. The number of arriving airplanes into Denver, however, had been restricted. The engineered performance standard for the weather conditions that existed at Denver on the day of the accident was 33 aircraft per hour. Early in the morning on the day of the accident, the flow controller from the central flow control facility in Washington, D.C., and a flow controller in Denver agreed on an acceptance rate. An entry representing 36 aircraft per hour was then entered into a computer at the central flow control facility, which was interfaced with all of the appropriate ARTCC computers around the country. Departure clearance times were then electronically distributed to all ARTCCs and then relayed to various approach controls within the centers' airspace. Airplanes were then departed from locations throughout the country at preplanned times, so that their arrival into Denver would be at or below the agreed upon acceptance rate. Thirty-six aircraft per hour had been given permission to depart for Denver. Because of last-minute schedule changes and cancellations, the actual number of aircraft being delivered per hour to the Denver Tower throughout the day was about 20. According to the ATC recorded radar data, the actual number of flights was 29 from 1 hour before the accident to the time of the accident.

### 1.17.3 Effects of Airframe Contamination on Airplane Performance

Several articles published by McDonnell-Douglas and testimony taken during the Safety Board's public hearing concerning this accident indicated that small accumulations of ice on the top or leading edges of wings can seriously degrade the lifting capability of the wing. According to McDonnell-Douglas, distributed roughness elements having a height of only 1/10,000 of the wing chord can adversely affect the maximum lift coefficient and significantly increase the stall speed. This height corresponds to about 0.015 inch on a DC-9 type airplane. As an example, a wing surface roughness of 0.03 inch thickness may increase the stall speed from 128 knots to as high as 152 knots indicated airspeed. In addition, operation with ice-contaminated wings may result in increased pitch sensitivity and/or roll oscillation. Normal control inputs may result in greater than normal pitch responses and roll oscillations may require control wheel deflections to counter the roll, resulting in spoiler actuations which further reduce the lifting capability of the wings on the DC-9. Moreover, DC-9-10 series airplanes, such as N626TX, are even more susceptible to such control problems because they lack slats or other leading edge devices which tend to suppress the adverse effects of small levels of contamination. In addition, asymmetrical contamination may result in the unexpected and premature stall of one wing only, with resultant wing drop off. One McDonnell-Douglas article<sup>3</sup> states:

<sup>3</sup>Burumby, Ralph E., *Wing Surface Roughness--Cause and Effect in DC Flight Approach #32*, Flight Development Group, Douglas Aircraft Company, McDonnell-Douglas Corporation, Long Beach, California, January 1979



... an airplane affected by wing surface roughness will stall prematurely, possibly before reaching the angle of attack for stall warning actuation. Further, any reduction in lift at a given angle of attack will obviously require a higher than normal airplane angle of attack to produce the desired amount of lift. This could, for example, require rotation to a higher than normal takeoff pitch attitude in order to achieve a normal liftoff and climb. Unfortunately, the higher angle of attack further reduces the already degraded margin to stall.

Title 14 CFR 121.629 states:

(a) No person may dispatch or release an aircraft, continue to operate an aircraft en route, or land an aircraft when in the opinion of the pilot in command or airplane dispatcher (domestic and flag air carriers only), icing conditions are expected or met that might adversely affect the safety of the flight.

(b) No person may take off an aircraft when frost, snow, or ice is adhering to the wings, control surfaces, or propellers of an aircraft.

In addition, 14 CFR 91.209, states

(a) No pilot may take off an airplane that has--

- (1) Frost, snow, or ice adhering to any propeller, windshield, or power plant installation, or to an airspeed, altimeter, rate of climb, or flight attitude instrument system;
- (2) Snow or ice adhering to the wings, or stabilizing or control surfaces; or
- (3) Any frost adhering to the wings, or stabilizing or control surfaces, unless that frost has been polished to make it smooth.

\* \* \* \* \*

In December 1982, following several icing-related takeoff accidents involving transport category and general aviation airplanes, the FAA provided extensive guidance on wing contamination in its 37-page Advisory Circular (AC) 20-117. In essence, the AC reaffirms the necessity of adherence to the "clean airplane concept" in flight operations. The AC states that the only way to insure that an airplane is free from surface contaminants is through close visual inspection before it actually takes off. According to the circular, the many variables affecting ice formation (AC 20-117 lists 13 significant ones) preclude a pilot from (1) assuming that his airplane is clean simply because certain precautions have been taken or certain ambient conditions exist, and (b) assuming his airplane is clean simply because he is within a certain arbitrary time frame between the last inspection of the airplane and takeoff.

Following the Air Florida Boeing 737 accident of January 13, 1982,<sup>4</sup> the Safety Board recommended on January 28, 1982, that the FAA:

<sup>4</sup>Aircraft Accident Report--Air Florida, Inc., Boeing 737-222, N62AF, Collision with 14th Street Bridge, Near Washington National Airport, , Washington, D.C., January 13, 1982 (NTSB-AAR-82-8)

A-82-7

Immediately review the predeparture deicing procedures used by all air carrier operators engaged in cold weather operations and the information provided to flightcrews to emphasize the inability of deicing fluid to protect against reicing resulting from precipitation following deicing.

In response, the FAA immediately transmitted the recommendation to all air carriers. Later in that year, the FAA requested that each *principal operations inspector* actively review each air carrier's manuals and guidance on cold weather operations. The standards for this review included pertinent FARs, advisory circulars, and air carrier operation and maintenance bulletins.

**1.17.4.1 Anti-Ice Protection**

Based upon the high frequency of winter operations in Europe, the Association of European Airlines (AEA) has provided guidance for anti-ice, as opposed to deice, protection for airplane on the ground. The 38 percent glycol solution was adequate to deice flight 1713, but provided little anti-ice protection, according to the AEA guidance. The AEA data indicate that the protection time could have been extended by a factor of 2.8 if a maximum effective strength glycol solution had been applied at the deice pad following the deicing. Other types of anti-ice fluids (type II or thixotropic fluids)<sup>5</sup> could have increased the anti-ice protection time by a factor of 8. However, to use the type II fluid, most U.S. operators would be required to modify their deicing fluid application equipment.

**1.17.5 Wingtip Vortices and Flight 1713**

A Delta Airlines Boeing 767 touched down on runway 35R, the offset parallel runway at Denver, approximately 3 minutes before the takeoff rotation of Continental flight 1713. The wing tip vortices<sup>6</sup> from the Delta airplane drifted in the general direction of flight 1713 during those 3 minutes. The touchdown point for the Boeing 767 was approximately 1,600 feet to the right side and about 1,900 feet ahead of the accident airplane's liftoff point. The crew of flight 1713 would have been unaware of the landing Delta airplane because they were not monitoring the tower frequency for runway 35R at the time.

The decay or dissipation of vortices in the atmosphere is a complex process that is influenced by several factors. These include air turbulence/crosswind speed, proximity of the vortex to the ground, distance traveled by the vortex and the original strength of the vortex. Although the hazards of wingtip vortices have been known for decades, study of vortex decay rate is ongoing.

According to FAA flight tests, wing generated vortices degrade with time and the vortex hazard to other airplanes generally disappears within 2 minutes. Current U.S. air traffic separation standards are based, in part, on these tests. More recent studies sponsored by the University of Hanover's Institute of Meteorology and Climatology, however, indicate that vortices generated by heavy airplanes have traveled as far as 1,700 feet laterally and have remained potentially dangerous for over 3 1/2 minutes. During these isolated instances, a crosswind component was found to be present and the atmosphere was found to be stable. These studies used laser doppler and tri-axial anemometers to measure vortex drift and decay.

<sup>5</sup>A thixotropic anti-icing fluid is more viscous than glycol fluids in common use in the United States. Thixotropic fluids are designed to slough off along with any ice or snow buildup during the takeoff roll. There is a slight takeoff performance penalty when they are used.

<sup>6</sup>The circulatory airflow around a wingtip, caused by air flowing outward laterally from the high pressure area on the under surface of the wing, and into the relatively low pressure area on the upper surface of the wing.

During the Safety Board's public hearing, a representative from the National Aeronautics and Space Administration (NASA) defined five conditions that must be met to support a theory of wake vortex encounter before the crash of Continental flight 1713:

1. The vortex generating airplane must be relatively heavy in order to generate strong and long lasting vortices.
2. The vortex must be generated at a sufficient height above the ground, in this case about 100 feet.
3. Atmospheric conditions must be consistent with those supporting long lasting wake vortices.
4. The vortex must encounter the accident airplane.
5. The vortex must still be of sufficient strength to result in loss of control at the encounter.

## 2. ANALYSIS

### 2.1 General

The airplane was certificated, equipped, and maintained in accordance with FAA regulations and company policies and procedures. The flightcrew was deemed qualified and certificated properly by the FAA, and the flight attendants were qualified for the flight.

The general life habits and recent events in the lives of the captain and first officer do not appear to have adversely affected their performance. Their specific activities during the 3 days preceding the accident also were uneventful. No evidence of adverse medical histories or chronic or acute ailments was discovered for either crewmember, and both were reportedly in good health at the time of the accident. Analysis of toxicological specimens obtained from the captain and the first officer did not detect any alcohol or other drugs.

There is no conclusive evidence that the captain's commute from his home in San Diego to Stapleton Airport on the morning of the accident adversely affected his performance. However, the Safety Board believes that commuting in proximity to reporting for duty is a practice which has potential to induce undue fatigue and stress and, therefore, should be discouraged.

The Safety Board examined Continental's DC-9 flight training, the first officer's flying experience, Continental's maintenance procedures and the mechanical integrity of the airplane, the weather affecting the flight, snow removal procedures at the airport and Continental's deicing procedures, air traffic control aspects affecting the flight, a possible encounter with wingtip vortices, and the possibility of wing contamination before and during takeoff. The dynamics of the aircraft's impact with the ground, postaccident survivability, and crash/fire/rescue activities also were analyzed.

Data retrieved from the FDR, ground scar examination, and the positions of wreckage fragments indicate that the left wingtip of the aircraft struck the ground first. At this point, the airplane was in a slight descent and in a bank angle of about 36° to the left. As the airplane continued to descend, the left wing disintegrated. The left side of the cockpit and forward fuselage contacted the ground next, about 250 feet after the initial impact point, and while the aircraft continued to roll to the left. As the fuselage rolled into an inverted position, the upper surface of the right wing began sliding along the ground about 500 feet after initial impact. At this juncture,

(white this out) evidence indicates that the tailcone/empennage departed the fuselage and was thrown to a point about 850 feet beyond initial impact. The fuselage and intact right wing then slid to a point about 1,000 feet beyond initial impact and slewed around to point in a southerly direction.

## 2.2 Continental DC-9 Training

Neither pilot had extensive experience in the DC-9, and the first officer had very little experience in any swept-wing turbojet airplane. The Safety Board believes that their specific flight training in Continental's DC-9 met and, in some instances, exceeded the minimum Federal requirements and accepted industry standards. The Continental DC-9 training program is one of the oldest at that airline.

The captain had no major problems during his instruction or his IOE although his IOE period was extended by the company. An FAA operations inspector who witnessed the IOE leg that caused the extension stated that he did not see the need for a Continental instructor to further observe the captain. Also, Continental training personnel voluntarily extended the IOE at the expense of a Continental flight instructor's time. The Safety Board is concerned, however, that demonstrating proficiency in all approach to stall maneuvers was waived by the FAA flight examiner on board during the captain's type rating check ride. Waiving of all approach to stall maneuvers is not in accordance with FAR 14 CFR Part 21, Appendix F, "Proficiency Check Requirements." Although the Safety Board has no reason to believe that the captain could not have performed the maneuvers proficiently on the checkride, the opportunity for FAA observation of his proficiency was lost.

The first officer, however, exhibited significant shortcomings during his DC-9 training. His instructors were conscientious enough to log specific problem areas in detail periodically during his time in training. These instructors also required the first officer to receive extra simulator time before they released him for line operations. While the first officer's skill as a pilot will be discussed later, the adequacy of his and the captain's training conformed to the FAA's requirements.

### 2.2.1 The First Officer's Initial Operating Experience

The first officer received all of his IOE while actually performing the duties of a second-in-command in accordance with Continental's policy. Therefore, the Safety Board believes that his IOE was not a factor in this accident. The Safety Board is concerned, however, that the current provisions of 14 CFR 121.434 permit completion of the IOE by a first officer while only observing from a jumpseat position in the cockpit. The regulation does not adequately satisfy the purpose and intent of the IOE and, in fact, reduces the opportunity for the "hands on" aspects of the IOE, and a loss of the check pilot's ability to evaluate the performance of the first officer.

Under the present FAA regulations, it is possible, depending on the simulator used in initial training, that the first time a first officer touches the controls of an actual airplane could be with a full load of passengers aboard and with an inexperienced captain in the left seat. In such a case, it would be legal for the first officer to perform the flying pilot's duties without having accrued any actual airplane flight time whatsoever. The Safety Board believes that this possibility is unacceptable and believes that the regulations should be amended to eliminate the provision which permits the completion of all IOE by a second in command from an observer's position in the jumpseat.

## 2.3 Airport Snow Removal

The Safety Board believes that snow removal at Stapleton International Airport was not a factor in this accident. According to several witnesses, runway 35L had been adequately plowed earlier in the day. According to the AOM who drove a truck onto the runway less than 2 minutes after flight

1713 crashed, the condition of the runway, in fact, had been improving up to the time of the accident. The runway condition had been improving because the runway was in heavy use before the accident and the ambient temperature was close to the freezing level. Although the crew that took off before flight 1713 stated that "there was a little clutter on the runway," no evidence of significant contamination could be found by the Safety Board. In addition, and most importantly, data from the FDR indicated that the takeoff acceleration of flight 1713 was normal.

## **2.4 Wingtip Vortices**

The encounter with a wing tip vortex from the landing Boeing 767 on runway 35R was eliminated as a probable cause in this accident when the Safety Board examined and eliminated as viable factors those conditions that would have made it possible for dangerous vortices to intercept the flightpath of flight 1713.

### **2.4.1 Wake Vortex Factor 1: Airplane Weight**

The vortex generating airplane must be relatively heavy to generate strong and long lasting vortices. The heavier an airplane is, the stronger its wingtip vortices will be. The Boeing 767 is classified as a "heavy" airplane for increased air traffic control separation purposes because its maximum takeoff gross weight can conceivably be above 300,000 pounds. As examples, heavy airplanes, such as the Boeing 747 or the military C5-A, may have landing weights over 500,000 pounds. The weight of the landing Delta B-767, however, was only 232,000 pounds. Therefore, although labeled a "heavy" airplane, the Delta B-767 was almost 70,000 pounds under the actual definition of a heavy airplane. To further illustrate this point, another Boeing product, the Boeing 757 can fly at weights of 232,000 pounds and yet it would never be considered a "heavy" airplane for ATC separation purposes because its maximum takeoff gross weight does not approach 300,000 pounds. All the experimentation cited in this section is based on measurements of vortices created by Boeing 747 class airplanes.

### **2.4.2 Wake Vortex Factor 2: Vortex Generation Altitude**

According to NASA and Department of Transportation (DOT) testimony, any vortex which would have affected flight 1713 would have been generated at a sufficient height above the ground to survive a sufficient time to reach the DC-9. In this case, any vortices originating below about 100 feet above the ground (which would be generated as the Boeing 767's altitude dropped below 100 feet during the landing descent) would decay rapidly. In other words, airplane wake vortices generated near the ground would decay much more rapidly than those generated above the airplane's approximate ground effect altitude. Wake vortex tracking test data show that in less than 1 percent of the flights observed, vortices generated by landing airplanes of the Boeing 747 class at 100 feet above ground level traveled over 900 feet laterally. For heavy airplanes at 70 feet, vortices rarely traveled laterally as far as 850 feet. In both NASA and DOT studies, the vortex strengths at 850 to 900 feet laterally from the origination point were extremely weak and not considered dangerous. In another study, DOT personnel tracked vortices from heavy airplanes that were taking off. Typically a takeoff configured airplane operates at greater gross weights and reduced flap settings and will generate stronger vortices than will a landing configured airplane of the same type. In this study, vortices were never detected beyond 1,300 feet laterally when generated at 70 feet above the ground. The Safety Board therefore concludes that any strong wingtip vortex generated below 100 feet by the Boeing 767 could not have traveled the required 1,600 feet between runways 35R and 35L at Stapleton Airport and survived that distance as a vortex significantly strong and active to have adversely affected the control of flight 1713.

### 2.4.3 Wake Vortex Factor 3: Atmospheric Instability

Another, and perhaps the prime, requirement for a long lasting, strong vortex is a stable atmosphere. A stable atmosphere is defined by both the absence of turbulence and a stable temperature gradient. Precise atmospheric measurements are usually required to accurately determine the atmospheric stability. These precise measurements, and consequently a perfectly defined characterization of the atmosphere on November 15, were not available at Stapleton. However, general indications of the conditions were available. Testimony at the public hearing by a representative of NASA indicated that surface winds normally generate disturbing turbulence near the ground. The LLWAS data clearly showed wind speed and direction fluctuations (wind gusts) that were consistent with turbulence. Additionally, upslope snow storms, such as the one in progress at the time of the accident, normally result in a neutral atmosphere. In the presence of strong winds and a neutral atmosphere, meteorologists have concluded the airmass is usually turbulent. From these indications, the Safety Board concludes that a stable atmosphere did not exist at Stapleton at the time of the accident and that vortices from the landing Boeing 767 would be short lived.

### 2.4.4 Wake Vortex Factor 4: The Lack of a Vortex Encounter

Last, and obviously, a vortex of any strength whatsoever also would have had to encounter flight 1713 while the airplane was in rotation for takeoff or airborne for it to have been a factor in this accident. NASA and DOT sources indicate that a vortex segment from the downwind wing would move with the wind at the speed of the wind plus an additional lateral component of about 3 knots for about the first 30 seconds after its generation. The vortex ground speed would then gradually slow to that of the wind component. The vortex segment generated by the upwind wing would tend to move with the wind, but about 3 knots slower than the lateral wind component and then after about 30 seconds, gradually speed up to the speed of the wind component. After about 30 seconds, vortex segments would be moving at the speed of the wind and in the direction of the wind. (See figure 7.)

The points and times on figure 6 were derived from recorded airport surveillance radar plots of the two airplanes and indicate that the Delta Boeing 767 landed approximately 3 minutes before the first sound of a compressor surge from the DC-9. The wind vector, determined from the LLWAS sensor readings, was about 24° from the right of runway heading and is aligned in figure 7 with the diagonal lines. The diagonal line to the south represents the direction of travel of a vortex segment generated at 100 feet above the ground under these wind conditions. The diagonal line to the north represents the direction of travel of a vortex segment generated when the Boeing 767 touched down. Due to the characteristics of wingtip vortices, none are generated after the nosewheel of an airplane is on the ground.

The Safety Board believes that any vortex generated below 100 feet above the ground would have quickly dissipated. Therefore, the south diagonal line on figure 6 is the last possible path of a "strong" vortex, and the north line is the last possible path of any vortex before its complete dissipation. The length of the diagonal lines is not representative of the distance which a vortex may travel before dissipating. The vortex may dissipate at any position along the lines, depending on the atmospheric conditions. Initial abnormal events during the takeoff of flight 1713 occurred about 1415:37 when the airplane had just lifted off the ground. The recorded altitude dip is large, indicating a larger than normal pitch attitude at liftoff and there is also a small uncharacteristic drop in the vertical acceleration trace. Beginning at 1415:39.5, there was a sharp drop in the vertical acceleration trace, an abrupt heading trace change to the left, then an exclamation from one of the pilots, and then the first sound of a compressor surge. For a wake vortex segment from the Boeing 767 to have affected the DC-9 at 1415:39.5, when airplane control became questionable, the vortex segment would have had to have moved from the Boeing to the position represented by the point on flight 1713's flightpath marked "1st COMP STALL." As can be seen, that position is well clear of any expected vortex movement area.

### RELATIVE POSITIONS OF COA 1713 AND B-767

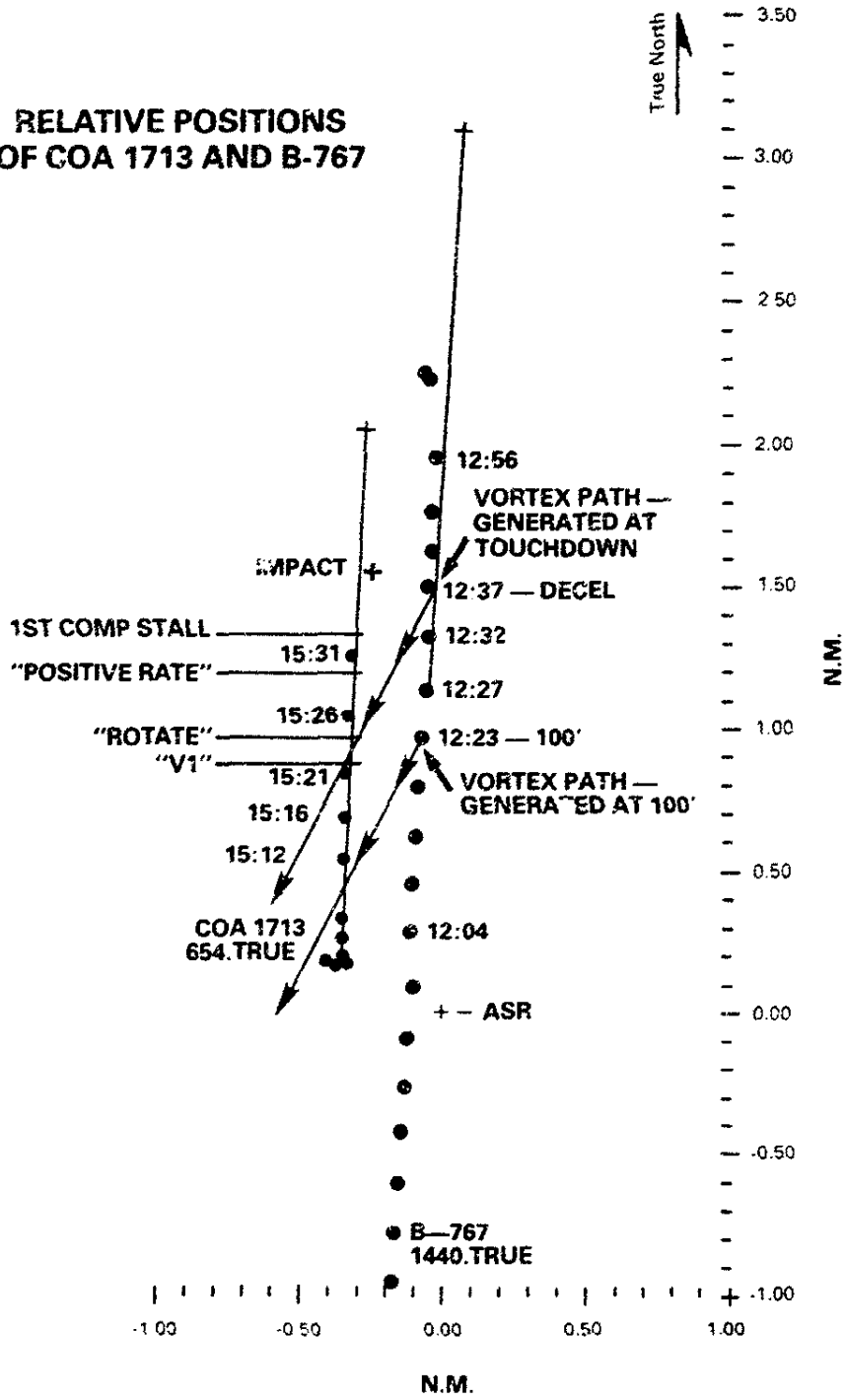

Figure 7.--Vortex path based on LLWAS sensor data.

In general, any vortex traveling on lines south of the "strong" vortex line could only have affected flight 1713 while it was still within the first 1,000 feet of its takeoff roll. In fact, it can be seen from the plot that all vortices from the B-767, if they survived the 1,600 feet of lateral movement between the runways at all, would have encountered the DC-9 while it was still on the ground.

Current available information on the generation, strength, life span, and direction of travel of the wingtip vortices from the landing Boeing 767 indicate that they could not have encountered flight 1713 during its short flight. Therefore, the Safety Board concludes that a wake vortex encounter was not the reason for flight 1713's unsuccessful takeoff. It should be noted that little wake vortex data exists for the B-767 and there is some possibility that its wake vortex may be longer lasting than its weight would suggest, although not as long lasting or as strong as the Boeing 747. Therefore, it is conceivable, but unlikely, that the B-767 could have produced a wake vortex strong enough to affect a DC-9 to some unknown degree, from a lateral distance of 1,600 feet. This could have occurred if, and only if, all the other conditions previously cited for potential encounter were present.

However, the Safety Board wishes to emphasize that it has not eliminated the possibility that on a different day with different conditions and different aircraft, a potential problem might exist concerning wingtip vortices. Therefore, the Board believes that the FAA should commence a research project to acquire data from dedicated sensors to determine what consideration, if any, should be given to wake vortices in a parallel offset runway situation.

## 2.5 Airplane Deicing and Subsequent Contamination

The Safety Board believes that the airplane was adequately deiced before it departed the deice pad. Evidence suggests that the combination system of fixed deicing snorkels and mobile deicing trucks used by Continental at Denver is quicker and more efficient than the use of deicing trucks alone.

Nevertheless, since the airplane was exposed to a moderate snowstorm in subfreezing conditions for approximately 27 minutes following deicing, the Safety Board believes that portions of the airframe became contaminated with a thin, rough layer of ice. The pilot of Continental flight 875 stated that he did not see any contamination on the wings of flight 1713. However, several surviving passengers on flight 1713 reported seeing some "ice" on engine inlets or in "patches" on the wing after deicing. These accounts suggest isolated fragments of contamination.

During precipitation in subfreezing ambient temperatures, ice can accumulate on airframe surfaces after a thorough deicing when the deicing solution evaporates, runs off, or is diluted with the precipitation. All three of these conditions occurred on the wings of flight 1713, with dilution of the deicing solution having been the predominant condition. Due to many variables involved, the Safety Board found it impossible to determine exactly where or exactly how much ice had formed on the wing and empennage surfaces of flight 1713. The Safety Board believes that enough wet snow (0.29 inch) fell on flight 1713 during the 27 minutes between deicing and takeoff to dilute the deicing fluid to the point where ice began to reform. This 0.29 inch of snow, if melted, would equate to about 0.032 inch of water.

The accumulated precipitation on the upper horizontal surfaces of the airplane probably would have been a combination of snow and melting snow or slush. Consequently, because of the dilution of the anti-icing fluid, the actual thickness of the slush probably would have been slightly greater than the water equivalent of the snow alone and would have frozen into a roughened surface. Even this modest amount of surface roughness on the wings of a DC-9-10 series wing could cause controllability problems according to McDonnell-Douglas.



The contamination of the airframe surfaces of flight 1713, as thin as it may have been, could have been delayed if the airplane had been anti-iced following the deicing. According to the Association of European Airlines, a full-strength glycol anti-icing application would have prevented any ice buildup 2.8 times longer than the 38 percent glycol deicing application that flight 1713 received.

Federal guidelines concerning deicing fluid type, temperature, consistency, and application methods are summed up in FAA AC 20-117. The AC thoroughly discusses deicing methodology in general use in the United States. It does not, however, incorporate more advanced deicing and anti-icing methods using "type II" deicing fluids that have been used by European countries for several years. The 1986 edition of the Association of European Airlines *Recommendations for De-/Anti-Icing of Aircraft on the Ground* includes specifications for ground deicing fluids, fluid dispensing equipment, quality control guidelines and procedures, application procedures and methods of ensuring proper interaction and communication between maintenance and flightcrews. The Safety Board acknowledges that the FAA, in conjunction with the Air Transport Association (ATA) and the Society for Automotive Engineers (SAE), is actively studying the advantages and disadvantages of the use of type II deicing fluids. Also, the Board notes that several U.S. manufacturers are now experimenting with other forms of advanced deicing and anti-icing systems and new mechanical ice detecting devices for aircraft. The Board encourages expedited research and testing in this area, under the sponsorship of the FAA. Also, the Board believes that, should type II or other advanced fluids prove safe for U.S. operations, their use should be highly encouraged by the FAA.

## **2.6 Aerodynamic Effects of Airframe Contamination and the Results of the Contamination on Flight 1713**

The Safety Board believes that ice contamination that formed on flight 1713 during the 27 minutes it waited to depart Stapleton was sufficient to raise the stall speed of the airplane and compromise its stability and the pilot's ability to maintain control. At the Safety Board's public hearing on this accident, a representative from McDonnell-Douglas stated that small amounts of upper wing ice may severely degrade the lifting capability of the wing and lead to loss of roll and pitch control on DC-9-10 series airplanes. He concluded that the DC-9-10 series and other airplanes, with and without leading edge slats, would be affected to varying degrees by small amounts of upper wing ice contamination. For example, granular ice of only 0.030 inch (similar to the roughness of 30-40 grit sandpaper) would degrade the maximum lifting capability of the DC-9 wing by about 20 percent. For a given increase in angle of attack, an ice contaminated wing would have a lesser increase of lift than would an ice-free wing. The stall speed would increase and the stall angle of attack would decrease, possibly to the point that the stall warning indicator (receiving its signals from angle of attack sensors, not airspeed sensors) would not activate before stall. Indeed, in the case of flight 1713, no stick shaker was heard on the CVR tape, although the airplane was in the stall regime before impact. In addition, if less than normal lift is available during the takeoff pitch rotation, the airplane may not be able to leave the ground either when expected or in a stable manner. In any case, the stall safety margin is significantly reduced.

Ice contamination also may produce roll oscillations and unexpected pitch-up tendencies during flight. Ice accumulations usually are not uniform and result in nonuniform lift degradations on the wings, horizontal tail, and, to a small degree, the fuselage. For example, a small section of ice on an otherwise contaminant-free wing or a small section of rougher ice on a contaminated wing, may be the first area on the wing to stall or produce less than normal lift. This uneven lift may result in the onset of roll, followed by pilot initiated counter airbrake and spoiler deflections which can quickly set up roll oscillations. On swept wing airplanes, contaminated outboard wing areas also can produce unexpected pitch-up tendencies because the outboard wing areas are usually behind the center of gravity of the airplane. When the wingtips stall, the inboard parts of the wings (ahead of the center of gravity) produce proportionally more lift and the nose pitches up. However, the

greater than normal pitch rate on flight 1713 was present during initial rotation (when the wings were unloaded) indicating that the high pitch rate was pilot-induced. Ice-induced pitch rates, on the other hand, result from loaded wings that just reach the localized stall angle of attack. The Safety Board is not aware of any service history or pilot reports describing DC-9-10 series ice-induced pitch-up tendencies.

The small amount of ice on the wings of the airplane contributed to significant controllability problems on flight 1713. Safety Board calculations show that a stall could have occurred on the accident airplane at 165 knots calibrated airspeed with 1.4 Gs on the airframe if there had been about a 20 percent reduction in maximum lifting capability. Flight 1713's maximum airspeed of about 165 knots was recorded on the FDR simultaneously with 1.4 Gs. At almost exactly the same time, an exclamation from a crewmember was recorded on the CVR. A 20 percent reduction in lift would have resulted from 0.03 inch of ice, which the Safety Board believes is at least the amount that could have accumulated in 27 minutes. Therefore, the Safety Board concludes that the accident was precipitated by the captain's failure to return for a second deicing after the extensive delay before takeoff because the upper wing surface contamination that existed was sufficient to cause the loss of control during the takeoff attempt.

## 2.7 Airplane Maintenance and Certification

The airplane was maintained in accordance with current Federal regulations and Continental maintenance policies. All airworthiness directives and service bulletins had been complied with. The one significant open discrepancy present at the time of the accident (the inoperative center fuel tank quantity gauge) did not contribute to the accident in any way because the center fuel tank contained only residual fuel during the flight.

The installation of red "STALL" lights on the glare shield of the airplane instead of amber "STALL WARN" lights was not in accordance with the original engineering order. In addition, the lack of a "Stall Comparator Failure" light on the annunciator panel was contrary to the engineering order. The filaments of both red "STALL" lights were found stretched, indicating that they were illuminated at impact. The Safety Board believes that the fact that the lights were red instead of amber and labeled incorrectly was not a causal factor in the crash. Also, the lack of a "Stall Comparator Failure Light" was not a causal factor in the crash.

The engine compressor surges noted on the CVR tape during the last seconds of the flight before impact were attributed to aerodynamic factors and not mechanical failures. Such surges have been noted in past accidents and incidents where the upper wing surfaces were contaminated and disturbed airflow from the wings entered the engine intake. Surges also have been noted on CVR recordings from accidents with no wing contamination. These surges occurred when the intakes were no longer aligned with the relative wind during dynamic maneuvering of the airplane, causing compressor blades to stall and subsequent surges. In all instances, the surges were the effect rather than the cause. Consequently, engine compressor surges were not a causal factor in this accident.

The lack of leading edge devices on the wings of the DC-9 airplane make it more vulnerable to performance degradation due to wing contamination; however, the Safety Board believes that the FAA and McDonnell-Douglas have adequately warned DC-9-10 series operators of such possible degraded flight characteristics through AC 20-117 and several articles on airframe contamination in McDonnell-Douglas publications.<sup>7</sup> In general, McDonnell-Douglas provided guidance for carefully inspecting for "almost undetectable amounts of ice," and the FAA regulations require that airfoil

<sup>7</sup>Brumby, *Wing Surface Roughness--Cause and Effect*, and Brumby, Ralph E. *Aerodynamics and Cold Weather Operations in DC Flight Approach #41*, Flight Test and Operations Group, Douglas Aircraft Company, McDonnell-Douglas Corporation, Long Beach, California, December 1982.

surfaces be free of contamination" before takeoff, which is adequately specific information for operators. Finally, airplane certification requirements for performance are based on airfoil surfaces that are not contaminated by ice, snow, or frost.

The Safety Board has investigated three previous DC-9-10 series icing-related accidents which were similar to the circumstances of the accident involving flight 1713.<sup>8</sup> In two of the accidents, ice was visible to the crews before takeoff; in the other accident, the crew failed to examine the wings before takeoff. The Safety Board believes that the November 15, 1987, accident again demonstrates that even small amounts of contamination on the upper surfaces of an airplane can seriously degrade lift. This accident underscores the critical importance for the pilot-in-command to ensure the surfaces are clean before every takeoff when in conditions conducive to contamination. The crew of flight 1713 also failed to examine the wings for contamination before takeoff. Therefore, the Safety Board believes that there is no justification for questioning the FAA certification of a DC-9-10 series airplane.

## 2.8 The First Officer's Actions During Rotation

The first officer's poor rotation technique probably contributed to the loss of airplane control. Evidence of trouble during the takeoff rotation was apparent from data recovered from the FDR. The altitude dip associated with pitch rotation in a DC-9-14 airplane is normally about 50 to 60 feet below field elevation, consistent with a pitch angle of about 6° during liftoff. Under normal circumstances, the magnitude of the dip is proportional to the pitch attitude of the airplane while it is still on the ground. The pitch rate defines the initial slope of the dip. For the accident flight, the dip was about 120 feet, indicating a pitch attitude of about 14° while the airplane was very close to the ground. Additionally, the pitch rate appeared to be over 6° per second, twice the recommended rate. The Safety Board examined the FDR altitude traces from the six previous flights of the accident airplane and found routine altitude trace dips for all six. Comparing these altitude trace dips with the trace dip on the accident flight, it appears that the first officer rotated the airplane about twice as fast as normal or recommended.

Greater than normal pitch rates result in the achievement of greater than normal angles of attack during the transition from ground roll pitch angle to the target climb pitch angle. While the airplane is on the ground, the angle of attack equals the pitch angle. The airplane normally leaves the ground at about 6° of pitch angle, and this angle continues to increase to the target climb angle of about 15° for initial climb. The angle of attack will also increase during this maneuver, but at a slower rate. Once the pitch angle is stabilized and the climb angle is starting to increase, the angle of attack will typically decrease. For a typical takeoff with a 3° per second rotation rate, the maximum angle of attack achieved will be about 9°. If the rotation rate is 6° per second, as on the accident airplane, the maximum angle of attack achieved may rapidly increase to about 12°, which is very close to the normal stall angle of attack of about 14° on the DC-9-10 series airplane. However, ice contamination probably lowered the actual stall angle of attack on the accident airplane to some angle less than 14°. As a result, the wing began to stall and the airplane began to roll. The stall warning stick shaker did not activate because of the previously discussed reduced angle of attack due to wing contamination. The stall was probably precipitated by rapidly rotating the airplane into an unacceptable angle of attack.

The 24-day period, which had elapsed since the first officer's last flight trip sequence, was excessive for a pilot of limited experience. Although it cannot be determined to what extent this may have affected the first officer's performance, the Safety Board believes that this extended

<sup>8</sup>Field Accident Briefs: *Trans World Airlines, Inc., Newark, New Jersey, November 27, 1978* (No. 4-0030) and *Airborne Express, Inc., Philadelphia, Pennsylvania, February 5, 1985* (No. 2662), and *Aircraft Accident Report-Ozark Air Lines, Inc., Douglas DC 9-15, N9742, Sioux City Airport, Sioux City, Iowa, December 7, 1968* (NTSB/CAK 70-23)

absence from flight duties probably eroded his retention of newly acquired knowledge and skills associated with his duties as a DC-9 first officer.

## 2.9 The Captain's Actions

The Safety Board notes several decision-making deficiencies of the captain of flight 1713. The Safety Board believes that he should have realized that he was exposing the airplane to airfoil contamination for too long a period and should have returned to the deicing pad for another deicing before takeoff. In addition, he showed poor judgment in allowing an inexperienced first officer to attempt a takeoff in weather conditions such as those that existed at Denver. Further, from data recovered from the CVR and the FDR, it appears that he did not attempt to arrest the first officer's rapid rotation of the airplane during the takeoff.

Although the captain was an experienced pilot with apparently better than average flying skills, he was relatively inexperienced as a captain on air carrier turbojet airplanes, and he had very little total flying time in the DC-9. He was not seasoned in either the supervision or judgment of first officers, nor was he familiar with the unique characteristics of the DC-9-10 series airplane in icing conditions. Although he was taught about DC-9 cold weather operations during his ground training and simulator sessions, he had never actually encountered ground icing conditions in a DC-9 before the accident. Also, he was remiss in at least two basic mission planning administrative duties of a Continental pilot (signing off the Read and Initial Book and telling the dispatcher of his need to declare an alternate airport before takeoff). In addition, he did not understand the intent of the company procedures concerning taxi from the gate through the deice pad and on to the runup pad. His failure to contact ground control for clearance to taxi to the deice pad precipitated a series of events that caused a portion of the 27-minute delay between deicing and takeoff. Following the accident, those procedures were modified to state that a flight should not taxi beyond the north side of concourse D until clearance is received from ground control.

Company procedures also required the captain to inspect the airplane if the takeoff is delayed for more than 20 minutes after deicing. The captain did not examine the wings or cause the wings to be examined even after 27 minutes had elapsed. Although there was no intercockpit discussion of this requirement, a comment about increasing engine power momentarily for engine anti-ice capability indicated that he was aware of the elapsed time since engine start and that he was aware of the need to increase engine power periodically to improve engine anti-icing airflow during icing conditions on the ground. Unfortunately, he appears to have linked icing conditions on the ground with optimum engine operation rather than optimum airfoil effectiveness. It is possible that the captain thought that since they were ready to take off approximately 20 minutes after deicing, a return to the deicing pad for more deicing was not necessary, in spite of the unanticipated additional delay of about 7 minutes.

The captain had never flown with the first officer and knew nothing of his flying skills or background, although he did realize that the first officer was new to Continental. He allowed the first officer to be the flying pilot on the first leg of this trip sequence into relatively poor weather, presumably so that he, the captain, would make the landing on the return leg to Stapleton, in perhaps equally poor weather. Although weather takeoffs are generally assumed to be less demanding than weather landings, and the general tradition is for two airline pilots to always "trade legs," a much wiser course of action would have been for the captain to have conducted the takeoff at Denver and then to have allowed the first officer to take over flying duties for the rest of that leg. The captain could then have flown the return leg and made the weather approach and landing back at Denver.

## 2.10 Crew Pairing

The Safety Board also believes that the captain's basic inexperience as a DC-9 pilot together with his inexperience as a captain supervising the actions of first officers left him unprepared for the rapid rotation by the first officer into the aerodynamic stall regime. A more experienced DC-9 captain may have been better able to (a) notice that a rapid rotation was occurring, (b) arrest the rotation by blocking the yoke, and finally, (c) perhaps allow the airspeed to build up to the point where the takeoff could be successfully completed.

In summary, the Safety Board believes that the pairing of pilots with limited experience in their respective positions can, when combined with other factors, such as adverse weather, be unsafe and is not acceptable. The Safety Board believes that although the pilots of flight 1713 had previously demonstrated competence in their duties, compromises in the decision-making process occurred as a result of inexperience in their respective positions. Subsequently, their pairing on the same flight was a factor in the accident.

As a result of its investigation of three commuter air carrier accidents,<sup>9</sup> the Safety Board recommended that the FAA:

### A-86-107

Issue an Air Carrier Operations Bulletin-Part 135, directing all Principal Operations Inspectors to caution commuter air carrier operators that have instrument flight rules authorization not to schedule on the same flight crewmembers with limited experience in their respective positions.

The FAA complied with the recommendation by issuing Air Carrier Operations Bulletin (ACOB) No. 87-2, *Commuter Flightcrew Scheduling*. The ACOB directed all principal operations inspectors (POI) to caution commuter air carrier operators who have instrument authorization not to schedule a flight crewmember with limited experience in their respective positions on the same flights.

The Safety Board is pleased to note that following this accident the FAA again embraced the concept of establishing minimum experience levels when pairing pilots for scheduling purposes. In January 1988, the FAA issued a similar ACOB to the POIs of major air carriers operating under Part 121, recommending that operators establish procedures which would prevent pairing inexperienced crewmembers on the same flight.

The rapid growth of the aviation industry at a time when fewer experienced pilots are in the workforce has reduced the opportunity for a pilot to accumulate experience before progressing to a position of greater responsibility. This loss of "seasoning" has led to the assignment of pilots who may not be operationally mature to positions previously occupied by highly experienced pilots. An operational safeguard to reduce the effect of these circumstances would be to establish a requirement prohibiting the scheduling or pairing on the same flight of crewmembers with limited experience in their respective positions. Operational limitations in other unusual circumstances, such as the placement of a new type of aircraft into service, should be developed, but the primary method by which adverse pairings should be avoided should be determined by the regulation of airline scheduling policies. The Safety Board believes that the time has come for the FAA to establish, and the industry to accept, such a requirement.

<sup>9</sup>Aircraft Accident Reports: Bar Harbor Airlines Flight 1808, Beech B-99, N300WF, Auburn-Lewiston Airport, Auburn, Maine, August 25, 1985 (NTSB/AAR-86/06), Henson Airlines Flight 1517, Beech B-99, N339HA, Shenandoah Valley Airport, Grottoes, Virginia, September 23, 1985 (NTSB/AAR 86/07), and Simmons Airlines Flight 1746, an Embraer Bandeirante, EMB-110P1, N1356P, near Alpena, Michigan, March 13, 1986 (NTSB/AAR-87/02)

## 2.11 Sterile Cockpit Procedures

The Safety Board is also concerned that the captain and the first officer engaged in almost 3 minutes of nonpertinent social conversation about 4 minutes before takeoff. Technically, the nonpertinent social conversation was not a violation of CFR 121.542(b), the "sterile cockpit" regulation, because the aircraft was not moving. The Board, however, believes that engaging in social conversation would suggest inattention to more important details, such as the forthcoming takeoff and the condition of the airplane with respect to FARs that prohibit takeoff with airfoil surfaces contaminated with snow and ice and to company procedures that required the captain to inspect the airplane for contamination if the takeoff was delayed more than 20 minutes after deicing. This activity in conjunction with the flightcrew's failure to mention possible wing contamination since departure from the deicing pad leads the Board to believe that the company may not have placed sufficient emphasis on the reasons for sterile cockpit procedures.

## 2.12 Continental's Preemployment Screening

The Safety Board is concerned that Continental's background check of the first officer did not reveal he had been discharged by a previous employer because of an inability to pass a flying check ride. Contrary to fact, the background check characterized the first officer's work as "very good" and went on to state that he left that company on his own accord. The Board believes that had Continental been aware of the first officer's employment background it would have had the option of not hiring him in the first place or of emphasizing areas in his DC-9 training where he had previously demonstrated weakness. The Board believes that the FAA should require commercial operators to examine applicants' records of previous flight experience and their safety records through the use of FAA accident/incident files and enforcement history records. Furthermore, a review of the training and performance records of previous employers for at least the preceding 5 years should be mandated, and an examination of criminal and driver records should be included. The use of a civil release signed by each applicant would facilitate the release of information from previous employers who might be reluctant to provide it otherwise.

## 2.13 The Role of the Clearance Delivery and Ground Controllers and Continental Flight 594 in the Takeoff Delay of Flight 1713

The Safety Board believes that the air traffic control facility at Stapleton was unaware of the locations of Continental flights 594 and 1713 for extended periods of time after they began taxiing and that this lack of awareness contributed to the delay between deicing and takeoff for flight 1713. Procedural errors on the part of both flightcrews also contributed to this delay.

The airport was not equipped with ASDE, and the visibility varied somewhat but generally was such that tower personnel could not see beyond the ends of the terminal concourses at Stapleton. Not being able to in some manner see airplanes they are supposed to be controlling places a great burden on the controllers in the tower. Had the controllers been able to locate flights 594 and 1713 on the ramp via radar as they progressed to the takeoff position, the points of confusion and the subsequent takeoff delays may not have occurred. The Safety Board notes that Stapleton Airport is scheduled to have an ASDE-3 installed in 1989, a slip from its original installation date of September 1988. The installation and certification of the equipment should take about 4 months according to FAA sources. The Board is concerned, then, that this airport will have gone without ASDE through two winter weather seasons with associated periods of low visibility since this accident.

The controllers' actions can be reconstructed. As stated earlier, flight 1713 taxied to the deice pad without clearance and contacted the clearance delivery controller for a frequency change to ground control and eventual clearance from the deice pad at 1351:12. The clearance delivery controller received the radio call, looked at the flight progress strip for the flight, saw no markings

on it indicating the location of the airplane on the airfield, and assumed the flight was taxiing from the gate, despite the fact that the phrase by the aircrew "from the ice pad" is clearly heard later on the recorded air traffic control audio tapes. He then annotated the strip with a mark indicating the flight was going to the deice pad and passed it on to the ground controller.

The ground controller then issued the clearance: "Continental 1713 left side taxi to the pad give way to two companies on the south side of delta goin' into there it's an Airbus and a ah MD-80." The issuance of this clearance was procedurally correct since due to the clearance delivery controller's mark on the strip he believed that the flight was still at its gate. His phraseology, however, was ambiguous because he did not specify deice pad as opposed to runup pad (at the end of the runway). The crew of flight 1713 may have assumed that he meant runup pad and, therefore, would have assumed the clearance was logical. Had he specified deice pad, the flightcrew may have noticed the point of confusion, enlightened the ground controller of their actual location, and entered the known takeoff lineup to take off in a timely manner.

The fact that the tower personnel also were unaware of the location of Continental flight 594 added to the takeoff delay of flight 1713. At 1350:55, Continental flight 594 transmitted on ground control frequency, "Ground, Continental 594 is ready to taxi to deice." Possibly because the ground controller remembered already talking to this flight a few moments earlier, the ground controller cleared that flight directly to the end of the runway with the transmission: "Continental 594, watch for two companies inbound to there, taxi to the north side of the runup 35 left." The flight replied "594" but did not question the clearance and proceeded to taxi to the deice pad. The ground controller assumed the airplane was taxiing to the runway holding pad and, after a representative amount of time had elapsed, gave the flight progress strip to the local controller. The local controller, in turn, sequenced the strip into the takeoff lineup and later was confused when he could not get flight 594 to acknowledge his instructions at 1405:29 to taxi onto the runway for takeoff clearance. At 1408:07, flight 594 did contact the ground controller after the airplane was deiced, and the flight did contact the tower controller later for takeoff clearance.

The procedural errors of the clearance delivery controller, the ground controller, and the crew of Continental flight 594, when combined with the procedural errors of the crew of flight 1713, caused about 9 minutes of confusion and caused flight 1713 to take off 9 minutes later than it could have had all these errors not taken place. Therefore, this confusion was contributory to the accident cause.

## 2.14 FAA Flow Control Into Denver

At 1410, about 5 minutes before the accident, the tower cab coordinator stated to the approach controller, "still about a half dozen or eight are still out there [awaiting takeoff], you know we're still able to straggle them out, but I need a good solid four [miles separation on arriving airplane] coming across the fence." He later stated that he did not believe that eight airplanes waiting for departure on a day such as the accident day was excessive.

The approach control supervisor testified at the Safety Board's public hearing on the accident that the maximum number of arriving airplanes that had been established on the day of the accident was 33 per hour and that the number of airplanes that the ARTCC was actually delivering to Denver was about 30 per hour throughout the day. He stated that 30 was a comfortable number of arrivals to work with; however, all of the controllers from Denver tower testified that they believed that no more airplanes could have been worked in the hour before the accident. According to ATC recorded radar data, the actual number of arriving flights from 1 hour before the accident to the time of the accident was 29. According to the Safety Board's calculations, had a true 4.5-mile separation been used between arrivals, the amount of arrivals that the airport would have been able to accommodate during this same time would have been 25.9 flights. In other words, to keep the flow balanced between arrivals and departures, using 4.5 miles as a minimum separation between

arriving airplanes, for the purpose of departing one airplane between these arrivals, an inbound flow of a maximum of 26 flights per hour would have been required. It appears then that the 33 airplanes per hour from the FAA engineer performance standard is not a safe number for the conditions on the day of the accident. The Safety Board believes that the FAA should revise its flow management engineer performance standards to include reduced airport capacities which normally occur when deicing operations are in progress.

## 2.15 Survivability

This accident was classified as partially survivable because of the amount of occupiable space retained during the impact sequence, the low level of gradual decelerative forces that existed throughout the accident sequence (in some parts of the cabin), and the lack of any substantial post-crash fire in spite of the fact that one wing fuel tank disintegrated upon impact.

According to surviving passengers and physical evidence, a fireball, originating around row 11, swept aft through the cabin during the impact sequence. The fireball probably resulted from ignition of residual center fuel tank fuel, extinguished itself rapidly, and did not affect passenger escape. The snow and dirt that entered the cabin during the impact sequence may have prevented the fireball from igniting anything in the cabin. The moderate snowfall and cold temperature mitigated fuel vaporization and further prevented a sustained postcrash fire. In spite of the brevity of the fire, 10 survivors and 6 deceased passengers received first- or second-degree burns.

## 2.16 Crash/Fire/Rescue Activity

The Safety Board believes that the initial response by the City and County of Denver Fire Department to the accident site was timely and saved many lives. Fire department personnel arrived quickly enough to extinguish several small fires within the wreckage before they could spread to the fully fueled, intact right wing of the airplane. The rescue of surviving passengers, however, was hampered by inadequate equipment and the fact that the fuselage came to rest in an inverted position.

In the area of the aft tailcone exit, impact damage and debris delayed passenger evacuation 7 to 10 minutes. Contributing to the delay was the fact that outside rescuers were hampered by limited visibility around the hatch area. The only instruction printed on the outside of the hatch was the word "Pull" on a placard near the hatch release handle. The hatch was then upside down because the fuselage was inverted. To assist future rescue attempts, the Safety Board believes that the FAA should issue an airworthiness directive to require more complete operating instructions on the exterior side of the tailcone exit hatch of DC-9 airplanes. The instructions should include both actions that are required to unlock and open the hatch: (1) Pull the release handle and (2) Push the latch into the cabin. A precautionary instruction also should be included to advise rescuers that inward movement of the hatch may be blocked by occupants of the aft jumpseat.

Radio communications difficulties existed from the outset of the rescue effort. The airport command post vehicle was of no use to the initial incident commander because its radio was inoperative. Therefore, the city's hazardous materials vehicle was used instead. Also, this original Airport Command Post vehicle was used from the outset to shelter injured passengers. Portable radio communications were not possible between CFR units operating around the airplane due to the noise that was generated by three large heaters, gasoline-power units for four hydraulic jaws, and numerous portable lighting rigs. In addition, the engines of all vehicles at the accident site were running, which added to the general noise.

According to rescuers and passengers, insufficient blankets were available to protect some of the injured passengers from the weather. In addition, many of the medical personnel from local hospitals were dispatched to the scene without proper cold-weather clothing.



Following the accident, rescue personnel recommended changes or additions to their rescue equipment. They stated that such items as surgical scissors and knives would have been useful to cut upholstery and wiring within the airplane. Also, they recommended that larger, unpainted and sturdier wooden cribbing be available to help support heavy airplane structures. The cribbing used during the rescue was small (which meant they needed a lot of it), painted (which made it slick in the snowstorm), and made of pine (which allowed it to compress in use). Lastly, they had trouble separating triage tags because they were tangled and frozen together after getting wet, and they also had trouble writing with pens on the tags because the ink in the pens had frozen.

According to the physician in charge of injury triage, about 15 Continental personnel responded to the crash scene and became interspersed with flight 1713's "walking wounded." Their presence presented a problem during attempts to triage the injured because it was difficult to quickly determine those individuals who actually had been on board the airplane. According to the airport emergency plan, the Continental employees were supposed to have reported to fire station No. 1 to help administratively process uninjured passengers. The Safety Board understands the desire of company personnel to help in any way they can during the initial hours of a disaster such as this. However, it must be realized that the crash site is not the place for untrained individuals to be. Furthermore, aside from causing confusion during triage, the Continental employees placed themselves in physical danger by being so close to the wreckage, which could have caught fire at any moment.

Because major airplane accidents, such as this one with a combination of deceased, trapped, and mobile passengers are relatively rare, the Safety Board believes that the City and County of Denver in conjunction with professional organizations, such as the National Fire Protection Association and the American Association of Airport Executives, should disseminate the circumstances of the CFR operation on November 15, 1987, throughout the industry.

### 3. CONCLUSIONS

#### 3.1 Findings

1. The flightcrew and the flight attendants were properly FAA-certificated and deemed qualified for the flight by the FAA.
2. The airplane was certificated, equipped, and maintained in accordance with FAA regulations and company policies and procedures.
3. Continental's DC-9 training program met and, in some instances, exceeded the minimum Federal requirements and accepted industry standards.
4. Although the captain and the first officer were experienced aviators, the captain was not experienced in the DC-9, and the first officer was not experienced in the DC-9 or in any swept-wing turbojet airplane.
5. Due to the relatively low experience levels of both crewmembers in the DC-9, the pairing of these pilots was inappropriate.
6. The first officer had a record of performance difficulties before joining Continental and continued to have difficulty in Continental's DC-9 training program.
7. The first officer's absence from flight duties for 24 days before the accident probably eroded his retention of newly acquired knowledge and skills associated with his duties.
8. Continental's background screening for the first officer was inadequate because it failed to reveal significant training difficulties he experienced with other operators.
9. During the 27 minutes between deice and takeoff, the airplane accumulated an unknown amount of contamination on portions of its lifting surfaces during a moderate wet snowstorm.
10. The flightcrew of flight 1713 contributed to the delay before takeoff because they taxied without proper ATC clearance from the gate to the deice pad and from the deice pad to the runup pad for runway 35L.
11. The flightcrew of flight 594 contributed to the delay before takeoff because they taxied contrary to the ATC clearance from the gate to the deice pad.
12. ATC personnel contributed to the delay before takeoff because they failed to properly identify the location and destination of Continental flights 1713 and 594 as they taxied from their respective gates to the deice facility and from the deice pad to the runup pad for runway 35L.
13. ATC personnel allowed departing airplanes to remain on the ground too long during the snowstorm while allowing arriving airplanes to land at Stapleton.
14. During the 30 minutes before takeoff, the pilots of flight 1713 did not discuss airfoil surface contamination and they did not visually inspect the wings before takeoff.
15. Airport snow removal at Stapleton was adequate at the time of the accident.

16. Any wingtip vortex from the Boeing 767 that landed on runway 35R about 3 minutes before the accident would not have encountered flight 1713 while it was rotating for takeoff or while airborne.
17. The first officer rotated the airplane for takeoff at a rate about twice the normal rate, and the captain failed to arrest this rapid rotation.
18. Several engine surges just before impact were attributed to disturbed airflow into the intakes due to the unusual attitude of the airplane.
19. Shortly after the airplane became airborne, a portion of the wing stalled and the airplane descended to the ground.
20. Initial crash/fire/rescue response was timely, but rescue activities were hampered by the position of the wreckage, adverse weather conditions, and equipment difficulties.
21. By applying a maximum effective strength glycol solution after deicing, anti-ice protection could have been increased by a time factor of 2.8 over the 38 percent glycol solution used on flight 1713.

### **3.2 Probable Cause**

The National Transportation Safety Board determines that the probable cause of this accident was the captain's failure to have the airplane deiced a second time after a delay before takeoff that led to upper wing surface contamination and a loss of control during rapid takeoff rotation by the first officer. Contributing to the accident were the absence of regulatory or management controls governing operations by newly qualified flight crewmembers and the confusion that existed between the flightcrew and air traffic controllers that led to the delay in departure.

#### 4. RECOMMENDATIONS

As a result of its investigation, the Safety Board made the following recommendations:

--to the Federal Aviation Administration:

Until such time that guidelines for detecting upper wing surface icing can be incorporated into the airplane flight manual, issue an air carrier operations bulletin directing all principal operations inspectors to require that all McDonnell Douglas DC-9-10 series operators anti-ice airplanes with maximum effective strength glycol solution when icing conditions exist. (Class II, Priority Action) (A-88-134)

Expedite the evaluation of the effectiveness of Association of European Airlines guidelines concerning the use of European types I and II deicing and anti-icing fluids. If European methodology is more effective than current U.S. methodology, incorporate their guidelines into the next version of Advisory Circular 200-17. (Class II, Priority Action) (A-88-135)

Require all DC-9-10 series operators to establish detailed procedures for detecting upper wing ice before takeoff. (Class II, Priority Action) (A-88-136)

Establish minimum experience levels for each pilot-in-command and second-in-command pilot, and require the use of such criteria to prohibit the pairing on the same flight of pilots who have less than the minimum experience in their respective positions. (Class II, Priority Action) (A-88-137)

Amend 14 CFR 121.434 to require that a second-in-command pilot complete initial operating experience for that position while actually performing the duties of a second-in-command under the supervision of a check pilot. (Class II, Priority Action) (A-88-138)

Review and revise, as necessary, the engineer performance standards for appropriate airports to account for the reduced airport capacities that occur when deicing operations are in progress. (Class II, Priority Action) (A-88-139)

Initiate a research project to acquire data from dedicated sensors to determine what consideration, if any, should be given to wake vortices in a parallel offset runway situation. (Class II, Priority Action) (A-88-140)

Require commercial operators to conduct substantive background checks of pilot applicants which include verification of personal flight records and examination of training, performance, and disciplinary records of previous employers and Federal Aviation Administration safety and enforcement records. (Class II, Priority Action) (A-88-141)

Issue an airworthiness directive to require more complete operating instructions on the exterior side of the tailcone exit hatch of DC-9 airplanes. The instructions should include both actions that are required to unlock and open the hatch: (1) PULL the release handle and (2) PUSH the hatch into the cabin. A precautionary instruction also should be included to advise rescuers that inward movement of the hatch may be blocked by occupants of the aft jumpseat. (Class II, Priority Action) (A-88-142)

--to the National Fire Protection Association:

Advise the Technical Committee on Airplane Rescue and Fire Fighting Operational Procedures of the problems identified during the investigation of the airplane accident at Denver, Colorado, on November 15, 1987, with a view toward developing additional information on emergency access areas for airplanes that may rest in unusual attitudes and the advisability and safety of defueling while passengers are trapped in and under the fuselage. (Class II, Priority Action) (A-88-143)

--to the American Association of Airport Executives and the Airport Operators Council International, Inc.:

Advise members of the circumstances of the emergency response to the airplane accident at Denver, Colorado, on November 15, 1987, and urge them to correct such problems as crash/fire/rescue (CFR) personnel training and inadequate CFR equipment. (Class II, Priority Action) (A-88-144)

--to Continental Airlines Inc.:

Implement procedures to conduct substantive background checks of pilot applicants which include verification of personal flight records and examination of training, performance, and disciplinary records of previous employers and Federal Aviation Administration safety and enforcement records. (Class II, Priority Action) (A-88-145)

Implement company procedures to monitor ground movements of aircraft at Denver Stapleton International Airport during periods of adverse weather when deicing operations are underway, and meter the release of company airplanes from the deicing facility to eliminate excessive delays following deicing. (Class II, Priority Action) (A-88-146)

**BY THE NATIONAL TRANSPORTATION SAFETY BOARD**

/s/ JAMES L. KOLSTAD  
Acting Chairman

/s/ JIM BURNETT  
Member

/s/ JOHN K. LAUBER  
Member

/s/ JOSEPH T. NALL  
Member

/s/ LEMOINE V. DICKINSON, JR  
Member

September 27, 1988

## 5. APPENDIXES

### APPENDIX A

#### INVESTIGATION AND HEARING

##### 1. Investigation

The National Transportation Safety Board was notified of the accident about 1500 eastern standard time on November 15, 1987. An investigative team was immediately assembled and dispatched to the scene. Investigative groups were established for operations, air traffic control, meteorology, systems structures, survival factors, human performance, powerplants, maintenance records, cockpit voice recorder, and aircraft performance.

Parties to the investigation were the Federal Aviation Administration (FAA); Continental Airlines Inc., McDonnell Douglas Aircraft Company; Pratt and Whitney; the Union of Flight Attendants; the City and County of Denver, Colorado; the American Association of Airport Executives; the National Air Traffic Controller's Association; and the National Fire Protection Association.

##### 2. Public Hearing

A 4-day public hearing was held in Golden, Colorado, beginning February 8, 1988. Parties represented at the hearing were the FAA; Continental Airlines; McDonnell Douglas; the Union of Flight Attendants; the National Air Traffic Controller's Association; the City and County of Denver, Colorado; and the Air Line Pilot's Association.

## 5. APPENDIXES

### APPENDIX A

#### INVESTIGATION AND HEARING

##### 1. Investigation

The National Transportation Safety Board was notified of the accident about 1500 eastern standard time on November 15, 1987. An investigative team was immediately assembled and dispatched to the scene. Investigative groups were established for operations, air traffic control, *meteorology, systems structures, survival factors, human performance, powerplants, maintenance records, cockpit voice recorder, and aircraft performance.*

Parties to the investigation were the Federal Aviation Administration (FAA); Continental Airlines Inc., McDonnell Douglas Aircraft Company; Pratt and Whitney; the Union of Flight Attendants; the City and County of Denver, Colorado; the American Association of Airport Executives; the National Air Traffic Controller's Association; and the National Fire Protection Association.

##### 2. Public Hearing

A 4-day public hearing was held in Golden, Colorado, beginning February 8, 1988. Parties represented at the hearing were the FAA; Continental Airlines; McDonnell Douglas; the Union of Flight Attendants; the National Air Traffic Controller's Association; the City and County of Denver, Colorado; and the Air Line Pilot's Association.

**APPENDIX B**  
**PERSONNEL INFORMATION**

**Captain Frank B. Zvonek, Jr.**

Captain Zvonek, 43, held airline transport pilot certificate No. 1898373, with type ratings for the CE-500 and DC-9, an airplane multiengine land rating, and commercial privileges for airplane single-engine land. He also held flight engineer certificate No. 1912062 with a turbojet powered aircraft rating. He held a first-class medical certificate, issued on October 8, 1987, with no limitations.

**First Officer Lee E. Bruecher**

First Officer Bruecher, 26, held airline transport pilot certificate No. 463331081 with type ratings for the BE-300, BE-1900, an airplane multiengine land rating, and commercial privileges for airplane single engine land. He also held flight instructor certificate No. 463331081CFI. He held a first-class medical certificate, issued on June 11, 1987, with no limitations.



## APPENDIX C

## COCKPIT VOICE RECORDER TRANSCRIPT

TRANSCRIPT OF A FAIRCHILD MODEL A-100 COCKPIT VOICE RECORDER  
S/N 2036 REMOVED FROM CONTINENTAL AIRLINES DC-9-14 WHICH WAS INVOLVED  
IN AN ACCIDENT AT DENVER STAPLETON AIRPORT ON NOVEMBER 15, 1987.

CAM	Cockpit area microphone voice or sound source
RDO	Radio transmission from accident aircraft
-1	Voice identified as Captain
-2	Voice identified as First Officer
-3	Voice identified as Female Flight Attendant
-?	Voice unidentified
CLR	Denver ATC Clearance Delivery
GND	Denver Stapleton Ground Controller
TWR	Denver Stapleton Local Controller (TOWER)
PA1508	Piedmont Flight Five oh Eight
COA1149	Continental Flight Eleven Forty-nine
COA1617	Continental Flight Sixteen Seventeen
COA65	Continental Flight Sixty-five
COA875	Continental Flight Eight Seventy-five
COA594	Continental Flight five ninety-four
UAL227	United Flight Two Twenty-seven
UNK	Unknown
*	Unintelligible word
@	Nonpertinent word
#	Expletive deleted
%	Break in continuity
( )	Questionable text
(( ))	Editorial insertion
-	Pause

NOTE: All times are expressed in Mountain Standard Time.  
Only those radio transmissions to and from the accident  
aircraft were transcribed while the flight was on clearance  
delivery and ground frequencies. After the flight switched to  
tower frequency, all radio transmissions were transcribed.

-1-

<u>INTRA-COCKPIT</u>		<u>AIR-GROUND COMMUNICATIONS</u>	
<u>TIME &amp; SOURCE</u>	<u>CONTENT</u>	<u>TIME &amp; SOURCE</u>	<u>CONTENT</u>
13:43:46	(( start of recording))		
13:45:09 CAM-1	say we're probably not gonna' use this guy any more are we		
13:45:13 CAM-2	naw I don't i wouldn't think		
13:45:14 CAM-1	why don't we go ah --**		
13:45:19 CAM-1	* why'd she make --		
13:45:29 CAM	((sound of deicing spray))		
13:45:37 CAM-1	it's like goin' through a car wash		
13:45:38 CAM	((sound of laugh))		
13:45:40 CAM	((sound of deicing spray))		
13:45:44 CAM-2	sounds like some came in		
13:45:52 CAM	((sound of a knock))		

AIR-GROUND COMMUNICATIONS

TIME & SOURCE      CONTENT

-2-

INTRA-COCKPIT

<u>TIME &amp; SOURCE</u>	<u>CONTENT</u>
13:45:54 CAM-2	yup
13:45:55 CAM-1	come in
13:45:56 CAM-3	check this out -- it came in the door - the deicing crud came through the door
13:46:00 CAM-2	tight seal
CAM-1	around around the edge
13:46:04 CAM-3	won't that won't that depressurize
CAM-1	no
13:46:06 CAM-2	no unh unh
13:46:07 CAM-1	we're not pressurized
13:46:08 CAM-2	yeah there's no pressure on the seal now when we pressurize the seal inflates

AIR-GROUND COMMUNICATIONS

-3-

<u>TIME &amp; SOURCE</u>	<u>CONTENT</u>	<u>TIME &amp; SOURCE</u>	<u>CONTENT</u>
13:46:13 CAM-3	oh it will-		
CAM-2	see that's why it came in		
13:46:17 CAM-3	just testing it - we'll remember that		
13:46:18 CAM	((sound of laugh))		
13:46:22 CAM	((sound of deicing spray))		
13:46:31 CAM-2	weird		
CAM	((sound of laugh))		
13:46:34 CAM	((sound similar to cockpit door being closed))		
13:46:44 CAM-2	I think I'm gonna go off * back here		
CAM-1	why		
13:46:47 CAM-2	I noticed they were talkin' to some other guy		
CAM-1	**		

AIR-GROUND COMMUNICATIONS

TIME & SOURCE      CONTENT

-4-

INTRA-COCKPIT

TIME & SOURCE      CONTENT

13:47:30  
CAM-1

blast off -

13:47:32  
CAM-2

yes sir

13:47:57  
CAM-1

before start

13:48:50  
CAM-1

\* they hooked up so long

CAM-2

ah--

13:49:01  
CAM-1

commence start

13:49:03  
CAM-2

okay

13:49:05  
CAM-1

before start checklist

13:49:06  
CAM-2

before start

13:49:08  
CAM-2

fuel quantity-flight papers

CAM-1

checked

AIR-GROUND COMMUNICATIONS

TIME & SOURCE                      CONTENT

-5-

INTRA-COCKPIT

TIME & SOURCE                      CONTENT

13:49:11  
CAM-2

hydraulics

CAM-1

checked on high

13:49:17  
CAM-2

sh parking brake

CAM-1

set

13:49:20  
CAM-2

pneumatic cross feeds

CAM-1

open

13:49:21  
CAM-2

beacon

CAM-1

on

CAM-2

packs

CAM-1

off

CAM-2

boost pumps

CAM-1

on

13:49:24  
CAM-2

pitot- windshield heat

CAM-1

on

AIR-GROUND COMMUNICATIONS

TIME & SOURCE      CONTENT

-6-

INTRA-COCKPIT

TIME & SOURCE      CONTENT

CAM-2      ignition

13:49:26

CAM-1

"A"

CAM-2

pneumatic pressure

13:49:28

CAM-1

up start 'em both

CAM-2

okay

13:49:33

CAM-2

cleared to start

13:49:34

CAM-1

okay

13:50:23

CAM-2

ready on two

CAM-1

two

13:50:47

CAM-1

well we got \* \*\*

CAM-?

\*

CAM-1

love it

CAM-2

yeah

APPENDIX C

INTRA-COCKPIT

TIME & SOURCE

13:51:11  
CAM

CONTENT

(( sound of power interruption to the cvr ))

-7-

AIR-GROUND COMMUNICATIONS

TIME & SOURCE

13:51:13  
RDO-1

clearance Continental seventeen thirteen taxi from the ice pad

13:51:17  
CLR

Continental seventeen thirteen monitor ground twenty one nine

13:51:20  
RDO-1

good day sir

13:51:25  
CAM-1

after start

13:51:29  
CAM-2

after start- start valve lights

CAM-1

out

13:51:31  
CAM-2

electrical system

CAM-1

is ah - checked

13:51:36  
CAM-2

external power and APU



AIR-GROUND COMMUNICATIONS

TIME & SOURCE                      CONTENT

-7A-

13:51:38 Continental seventeen  
GND                      thirteen left side taxi to  
the pad give way to two  
company's on the south side  
of Delta goin' into three  
it's an Airbus and a MD  
eighty

13:51:47  
RDO-1 Continental seventeen  
thirteen roger

INTRA-COCKPIT

TIME & SOURCE                      CONTENT

AIR-GROUND COMMUNICATIONS

TIME & SOURCE                      CONTENT

-8-

INTRA-COCKPIT

<u>TIME &amp; SOURCE</u>	<u>CONTENT</u>
13:52:07 CAM-2	ignition is off
13:52:12 CAM-2	engine anti-ice
13:52:17 CAM-2	on
13:52:18 CAM-2	packs - both in auto
13:52:21 CAM-2	door lights -
CAM-1	(there off)
13:52:26 CAM-2	gear door light
13:52:27 CAM-1	out
13:52:28 CAM-2	hydraulics -
13:52:31 CAM-2	cockpit door - sterile cockpit light
13:52:33 CAM-1	the're on

AIR-GROUND COMMUNICATIONS

TIME & SOURCE                      CONTENT

-9-

INTRA-COCKPIT

TIME & SOURCE                      CONTENT

13:52:34  
CAM-2

we're complete

13:53:16  
CAM-2

and ah we're talkin' to ground now

13:53:17  
CAM-1

right

13:53:37  
CAM-1

how do we look down there

13:53:38  
CAM-2

lookin' good on the right

13:53:39  
CAM-2

yes sir

13:53:49  
CAM-2

your wiper over there doesn't look too hot

13:53:51  
CAM-1

no

13:54:33  
CAM-1

you might tell him that we have a little  
standoff here

13:54:37  
CAM-2

alright

AIR-GROUND COMMUNICATIONS

TIME & SOURCE      CONTENT

-10-

INTRA-COCKPIT

TIME & SOURCE      CONTENT

he--he said somethin' about goin' by in the Airbus - the Airbus must be goin' \*

13:54:43  
CAN-2      I got that

13:54:46  
CAN-1      okay

13:54:47  
RDO-2      and ground seventeen thirteen

13:54:48  
GND      go ahead

13:54:50  
RDO-2      ah yes sir ah we've got a little stand off goin' here you say again you do want us behind the Airbus

13:54:55  
GND      yeah behind the Airbus I think ah he just out of the alleyway now they're goin' north bound

13:55:00  
RDO-2      ah roger sir

CAN-2      ah looks like this nine is --\*

AIR-GROUND COMMUNICATIONS

TIME & SOURCE                      CONTENT

-11-

INTRA-COCKPIT

TIME & SOURCE                      CONTENT

13:55:10 CAM-2 flaps and gear no smokin'

13:55:13 CAM-1 alright

13:55:20 CAM-2 you're lookin' good over here

13:56:21 CAM-1 \*\* guys over here

13:56:22 CAM-2 okay

13:57:52 CAM ((sounds of two short activations of the windshield wipers))

13:58:25 CAM-1 why don't you go to tower

CAM-2 \*

13:58:34 CAM (( flight started receiving tower transmissions))

13:58:34 TMR -- for takeoff wind zero one zero at one two touchdown correction three five left RVR two thousand

INTRA-COCKPIT

AIR-GROUND COMMUNICATIONS

TIME & SOURCE      CONTENT

TIME & SOURCE      CONTENT

-12-

13:58:51  
CAM-1      go ahead and run the taxi except for the flaps

13:58:54  
CAM-2      okay

13:58:55  
CAM-1      takeoff is up here remind me --

13:58:58  
CAM-2      (power)

13:58:59  
CAM-2      takeoff data and bug  
of

13:59:02  
CAM-2      we're at a go at eighty seven - bug one  
forty nine

13:58:40  
PA1508      cleared to go Piedmont five zero eight

13:58:41  
TWR      Continental eleven forty nine taxi into position and hold runway three five left report in position

13:58:45  
COA1149      Continental eleven forty nine

13:58:58  
COA1617      Continental sixteen seventeen is holdin' short do you want us short of the runway there or here at the pad

TWR      Continental sixteen seventeen short  
the runway up to and hold short please

AIR-GROUND COMMUNICATIONS

TIME & SOURCE      CONTENT  
13:59:02  
COA1617      sixteen seventeen

-13-

INTRA-COCKPIT

TIME & SOURCE      CONTENT

13:59:05  
CAM-1      set left

13:59:07  
CAM-2      set right

13:59:10  
CAM-2      flaps - we're gonna hold- stab trim set three point  
two -- knees clear

13:59:14  
CAM-1      yeah

13:59:20  
CAM-2      \*

13:59:23  
CAM-1      spoilers are checked

13:59:25  
CAM-2      anti-skid

13:59:27  
COA1149      Continental eleven forty nine in  
position ready to go

13:59:30  
TMR      thank you

AIR-GROUND COMMUNICATIONS

<u>TIME &amp; SOURCE</u>	<u>CONTENT</u>
--------------------------	----------------

-14-

INTRA-COCKPIT

<u>TIME &amp; SOURCE</u>	<u>CONTENT</u>
--------------------------	----------------

13:59:31 CAN-2	flight controls checked anti-skid armed -- yaw damp is that checked while we were taxiing
-------------------	--

13:59:36 CAN-1	affirmative
-------------------	-------------

13:59:37 CAN-2	flight instruments checked
-------------------	----------------------------

13:59:40 CAN-1	okay
-------------------	------

13:59:45 CAN-1	I do appreciate you keepin' up the *
-------------------	--------------------------------------

13:59:46 CAN	((sound of laugh))
-----------------	--------------------

13:59:48 CAN-2	and the APU do you want to go with it - on
-------------------	--

13:59:51 CAN-1	yes
-------------------	-----

13:59:53 CAN-2	* air conditioning is auto-shutoff is armed
-------------------	---

13:59:58 CAN-2	fuel heat --
-------------------	--------------



AIR-GROUND COMMUNICATIONS

TIME & SOURCE      CONTENT

13:59:59  
TWR      Piedmont five oh eight turn right heading zero one zero and contact departure good day

14:00:03  
PA1508      Piedmont five oh eight so long now

14:00:11  
UNK      hey six twenty six move it up will ya

14:00:50  
TWR      Continental eleven forty nine runway three five left cleared for takeoff wind zero one zero at one three RVR two thousand

14:00:54  
COA1149      eleven forty nine on the roll

-15-

INTRA-COCKPIT

TIME & SOURCE      CONTENT

14:00:01  
CAM-2      \*\*

14:00:05  
CAM-2      pneumatic cross feeds are off - closed

14:00:09  
CAM-2      Shoulder harness on - takeoff briefing we've got it.

14:00:13  
CAM-2      holdin' on the flaps

INTRA-COCKPIT

TIME & SOURCE                      CONTENT

14:00:59  
CAM-?                      (we're next)

-16-

AIR-GROUND COMMUNICATIONS

TIME & SOURCE                      CONTENT

14:00:56  
TMR                      Continental sixteen seventeen taxi into position and hold runway three five left report in position

14:01:01  
COA1617                      position and hold sixteen seventeen we'll give you a call when we're in position

14:01:04  
TMR                      Continental sixty five taxi up to and hold short

14:01:07  
COA65                      Continental sixty five roger up and hold short

14:01:48  
COA1617                      and sixteen seventeen is in position

14:01:50  
TMR                      thank you

14:02:10  
TMR                      Continental eleven forty nine contact departure good day

AIR-GROUND COMMUNICATIONS

TIME & SOURCE      CONTENT

14:02:12  
COA1149    eleven forty nine good day

14:02:34  
TWR        Continental sixteen seventeen three  
            (five left cleared for takeoff wind  
            zero one zero at one three RVR two  
            thousand two hundred

14:02:40  
COA1617    sixteen seventeen

14:02:41  
TWR        Continental sixty five taxi into  
            position and hold runway three five  
            left report in position

14:02:45  
COA65      position and hold three five left  
            Continental sixty five

14:02:49  
TWR        Continental five ninety four taxi up  
            to and hold short

14:02:55  
TWR        Continental five ninety four taxi up  
            to and hold short

-17-

INTRA-COCKPIT

TIME & SOURCE      CONTENT

14:02:46  
CAN-2      RVR two thousand two hundred

INTRA-COCKPIT

AIR-GROUND COMMUNICATIONS

-18-

TIME & SOURCE

CONTENT

TIME & SOURCE      CONTENT

14:03:00  
CAM-1

below my minimums - for landing

14:03:09  
CAM-1

we'll have to call dispatch when we get to Boise - to let 'em know

14:03:12  
CAM-2

alright

14:03:13  
CAM-1

high minimums - \* \*

14:03:17  
CAM-2

okay

14:03:33  
COA65

ah Denver tower Continental sixty five is in position runway three five left

14:03:36  
TWR

\*

14:03:54  
TWR

Continental sixteen seventeen contact departure good day

14:03:57  
COA1617

good day sir

AIR-GROUND COMMUNICATIONS

TIME & SOURCE                      CONTENT

-19-

INTRA-COCKPIT

TIME & SOURCE                      CONTENT

14:04:21                      CAM-1                      we're (not) gonna' get much slop between here and the end so why don't you go ahead and get flaps down

14:04:25                      CAM-2                      okay -flaps ten

14:04:26                      CAM                      ((sound similar to flap handle being moved))

14:04:30                      CAM-2                      taxi check complete

14:04:32                      CAM-1                      thank you

14:04:43                      CAM-1                      ah- if we got to do this for seven landings I tend to lose my enthusiasm --

14:04:47                      CAM-2                      yeah

14:04:48                      CAM-1                      -- tired --\*

14:04:49                      CAM-2                      yeah no kidding

14:04:54                      CAM-1                      \* this stuff just may not go anywhere it may hang in here for a couple of days

-20-

INTRA-COCKPIT

TIME & SOURCE

CONTENT

14:04:56  
CAN-2

uh huh

14:04:59  
CAN-1

stationary low like this

AIR-GROUND COMMUNICATIONS

TIME & SOURCE

CONTENT

14:05:13  
TWR

Continental sixty five three five left cleared for takeoff wind zero one zero at one five RVR two thousand two hundred

14:05:18  
COA65

cleared for takeoff three five left Continental sixty five

14:05:21  
TWR

Continental five ninety four taxi into position and hold runway three five left report in position

14:05:30  
TWR

Continental five ninety four taxi into position and hold three five left report in position

14:05:36  
TWR

Continental five ninety four how do you hear

AIR-GROUND COMMUNICATIONS

TIME & SOURCE      CONTENT

14:05:41  
TWR      Continental eight seventy five how do you hear me

14:05:43  
COA875      Continental eight seventy five loud and clear

14:05:45  
TWR      thank you can anybody see a MD-eighty goin' into position out there

14:05:48  
UNK      he ain't movin'

14:05:50  
TWR      Continental five ninety four tower

14:05:57  
TWR      Continental five ninety four Denver tower

14:06:00  
RDO-2      and Denver tower er yeah Denver tower Continental seventeen thirteen is number one DC-nine for Continental

-21-

INTRA-COCKPIT

TIME & SOURCE      CONTENT

14:05:53  
CAM-1      you might ah tell him that we're ah number one here on the north side

AIR-GROUND COMMUNICATIONS

<u>TIME &amp; SOURCE</u>	<u>CONTENT</u>
14:06:16 TWR	Continental five ninety four tower
14:06:23 TWR	Continental eight seventy five can you get around a company MD-eighty for the runway
14:06:25 COA875	Continental eight seventy five affirmative
14:06:27 TWR	Continental eight seventy five taxi into position and hold runway three five left report in position
14:06:30 COA875	Continental eight seventy five position and hold will call

-22-

INTRA-COCKPIT

<u>TIME &amp; SOURCE</u>	<u>CONTENT</u>
14:06:19 CAM-1	it didn't impress him at all
14:06:21 CAM-2	apparently not
14:06:33 CAM-1	is that the guy directly to our right



-23-

INTRA-COCKPIT

TIME & SOURCE                      CONTENT

14:06:50  
CAM-1

he's the guy they just cleared on

14:06:52  
CAM-2

yeah

AIR-GROUND COMMUNICATIONS

TIME & SOURCE                      CONTENT

14:06:36  
TWR

Continental eleven fifteen give your company a call tell 'em to raise Continental five ninety four please he's not talkin' to me

14:06:42  
TWR

Continental sixty five contact departure good day

14:06:44  
COAG5

Continental sixty five roger good day

14:06:56  
RDO-2

and Denver tower the number one Continental there at the runway is seventeen thirteen

14:07:01  
TWR

roger ah I have a Continental five ninety four would that be anybody --

14:07:05  
TWR

seventeen thirteen are you an MD-eighty

-24-

INTRA-COCKPIT

TIME & SOURCE                      CONTENT

14:07:21                      CAM-1                      okay I think we got 'em straightened out now

14:07:22                      CAM                      ((sound of laugh))

14:07:26                      CAM-2                      we'll see

14:07:28                      CAM-1                      get around to him

14:07:31                      CAM-1                      we'll probably follow him

AIR-GROUND COMMUNICATIONS

TIME & SOURCE                      CONTENT

14:07:07                      RDO-2                      negative sir DC-nine

14:07:13                      TWR                      Continental seventeen thirteen roger  
and a company seven thirty seven three  
hundred just passin' ya

14:07:17                      RDO-2                      affirm

14:07:18                      TWR                      alright thank you

14:07:29                      TWR                      you'll probably follow him

AIR-GROUND COMMUNICATIONS

TIME & SOURCE                      CONTENT

-25-

14:07:35  
COA875                      Continental eight seventy five is in position

14:07:44  
COA875                      tower Continental eight seventy five is in position

14:08:01  
COA875                      tower Continental eight seventy five is in position

14:08:04  
TMR                              thank you very much sir it's gonna be a couple minutes on the runway they're runnin' 'em a little bit tight to the right

14:08:09  
COA875                      okay

INTRA-COCKPIT

TIME & SOURCE                      CONTENT

14:07:32  
CAM-2                              yeah

14:07:40  
CAM-1                              I think he realizes what's goin' on too cause when he went by he went like this

14:07:43  
CAM-2                              yeah

INTRA-COCKPIT

TIME & SOURCE                      CONTENT

14:08:12                      CAM-1                      oh yeah

14:08:15                      CAM-2                      that's what the girl at the picnic said

14:08:17                      CAM-1                      a little bit tight on the right

((From 14:08:23 to 14:11:08, the captain and the first officer engaged in nonpertinent conversation and there were also no air traffic control transmissions during this time period))

14:11:06                      CAM-1                      suppose to run this thing up to seventy five percent every ten minutes

14:11:11                      CAM-1                      like all airplanes probably seventy five percent \*

14:11:15                      CAM-2                      that's good

*is correct.*

14:11:24                      COA594                      ah tower Continental five ninety four

14:11:26                      TWR                      yes sir go ahead

14:11:28                      COA594                      any ah - clutter on the runway

AIR-GROUND COMMUNICATIONS

TIME & SOURCE                      CONTENT

-26-

AIR-GROUND COMMUNICATIONS

TIME & SOURCE      CONTENT

14:11:30      TWR      I have had not had a runway condition report that is ah anywhere near recent

14:11:37      COA594      thank you

14:11:39      UNK      what is the sequence on the left one now tower

14:11:41      TWR      it'll be eight seventy five seventeen thirteen United two twenty seven TWA eighty one twenty four more later

-27-

INTRA-COCKPIT

TIME & SOURCE      CONTENT

14:11:48      CAM-1      more later

14:11:50      CAM-2      more later -

14:11:52      CAM-2      \*

14:11:53      CAM-1      boy the last two times they were firin' them out of here on both runways as fast as they could and it was just packed with airplanes everywhere -

INTRA-COCKPIT

TIME & SOURCE

CONTENT

-28-

14:12:00  
CAM-2

14:12:02  
CAM-1

14:12:07  
CAM-2

\*  
- a lot of cancellations today - a lot of people runnin' way late-

I'm always suprised at ah the delays they've got here

14:12:22  
CAM-2

I guess maybe it's --

14:12:25  
CAM-2

- the first day of the new hurry up type syndrome

AIR-GROUND COMMUNICATIONS

TIME & SOURCE

CONTENT

14:12:15  
TWR

Continental eight seventy five runway three five left cleared for takeoff wind zero one zero at one six runway visual range two thousand

14:12:20  
COA875

Continental eight seventy five on the roll

14:12:23  
TWR

and please report airborne

COA875

willco

AIR-GROUND COMMUNICATIONS

TIME & SOURCE      CONTENT

14:12:31  
TWR      Continental seventeen thirteen taxi into position and hold

14:12:33  
RDO-2      position and hold for seventeen thirteen

14:12:42  
PA-2      ladies and gentleman we have been cleared to taxi into position and hold on the runway we will be airborne very shortly flight attendants prepare the cabin for departure and take your seats

14:13:00  
COA875      Continental eight seventy five is airborne there is a little clutter on the runway

14:13:04  
TWR      Continental eight seventy five thank you continue on runway heading and contact departure control

-29-

INTRA-COCKPIT

TIME & SOURCE      CONTENT

14:12:57  
CAM-2      before takeoff brake selector ignition is override--

14:13:02  
CAM-2      takeoff announcement we got made transponder --

INTRA-COCKPIT

<u>TIME &amp; SOURCE</u>	<u>CONTENT</u>
14:13:05 CAM-2	- DME's are on -
14:13:10 CAM-2	and annunciator panel --
14:13:17 CAM-2	- a little crud
14:13:41 CAM-2	speeds - one thirty nine one forty five and one forty nine
14:13:49 CAM-2	departure is two three eight - and I got it over here too
14:13:55 CAM-1	don't slide

AIR-GROUND COMMUNICATIONS

<u>TIME &amp; SOURCE</u>	<u>CONTENT</u>
14:13:08 COAB75	good day
14:13:11 TWR	for who ever that was that asked company reports there is a little crud on the runway I don't know how to define that

-30-



-31-

AIR-GROUND COMMUNICATIONS

TIME & SOURCE                      CONTENT

TIME & SOURCE                      CONTENT

14:13:57  
CAM-1                      you might tell him we're in position

14:13:58  
CAM-2                      okay

14:13:59  
CAM-1                      he can't see us

14:14:01  
RDO-2                      and Continental seventeen thirteen is  
in position

14:14:02  
TWR                      thank you

14:14:04  
CAM-1                      okay red rover

14:14:06  
CAM-2                      (sound of laugh)

14:14:08  
CAM-2                      bend over and bark like a dog

14:14:10  
CAM                      ((sound of whistling))

14:14:22  
CAM-1                      got the brakes on you got the airplane -

AIR-GROUND COMMUNICATIONS

TIME & SOURCE                      CONTENT

-32-

INTRA-COCKPIT

TIME & SOURCE                      CONTENT

14:14:24  
CAM-2                      okay

14:14:25  
CAM-1

- I got the radio - run em' up a little bit before you release the brakes and let them stabilize

14:14:30  
CAM-2                      okay

14:14:31.3  
TMR                      Continental seventeen thirteen runway three five left cleared for takeoff wind is three six zero at one four runway visual range two thousand

14:14:38.8  
RDO-1                      cleared for takeoff Continental seventeen thirteen

14:14:41  
TMR                      United two twenty seven taxi into position and hold advise on runway

14:14:45  
UAL227                      United two twenty seven

14:14:46.4  
CAM                      ((sound of one cabin chime))



AIR-GROUND COMMUNICATIONS

<u>TIME &amp; SOURCE</u>	<u>CONTENT</u>
--------------------------	----------------

-34-

INTRA-COCKPIT

<u>TIME &amp; SOURCE</u>	<u>CONTENT</u>
--------------------------	----------------

14:15:39.1

CAM ((sound similar to someone taking a breath))

14:15:39.5

CAM ((sound similar to engine compressor stall))

14:15:39.8

CAM-2 #

14:15:40.2

CAM ((sound similar to engine compressor stall))

14:15:41.6

CAM ((sound of bang))

14:15:42.2

CAM ((sound similar to engine compressor stall))

14:15:43.0

CAM ((sound similar to engine compressor stall))

14:15:43.8

CAM ((sound of impact))

14:15:44.75

((end of recording))

APPENDIX D  
FLIGHT DATA RECORDER DATA

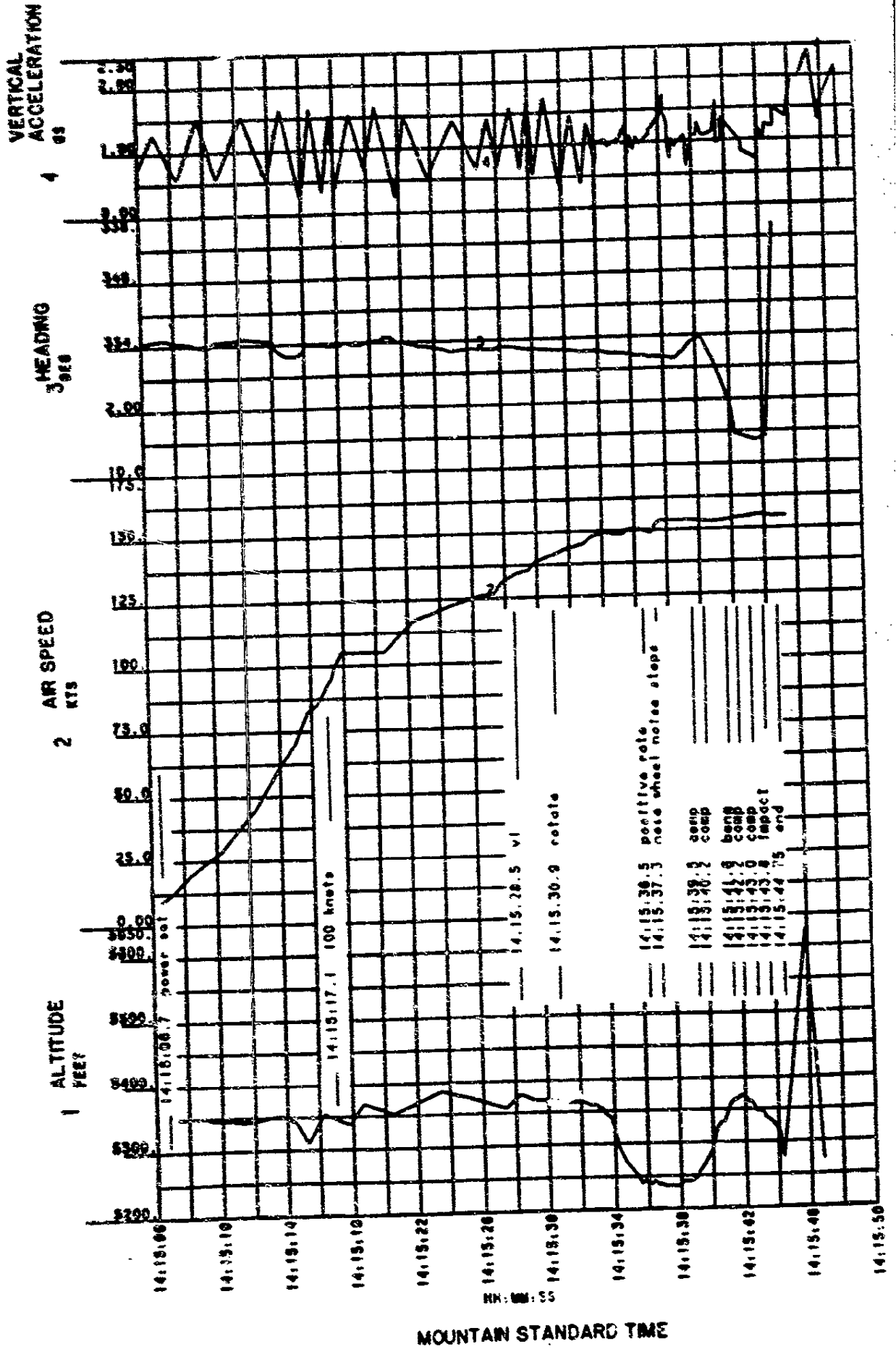

APPENDIX E  
FDR ALTITUDE TRACES FOR THE SIX PREVIOUS FLIGHTS

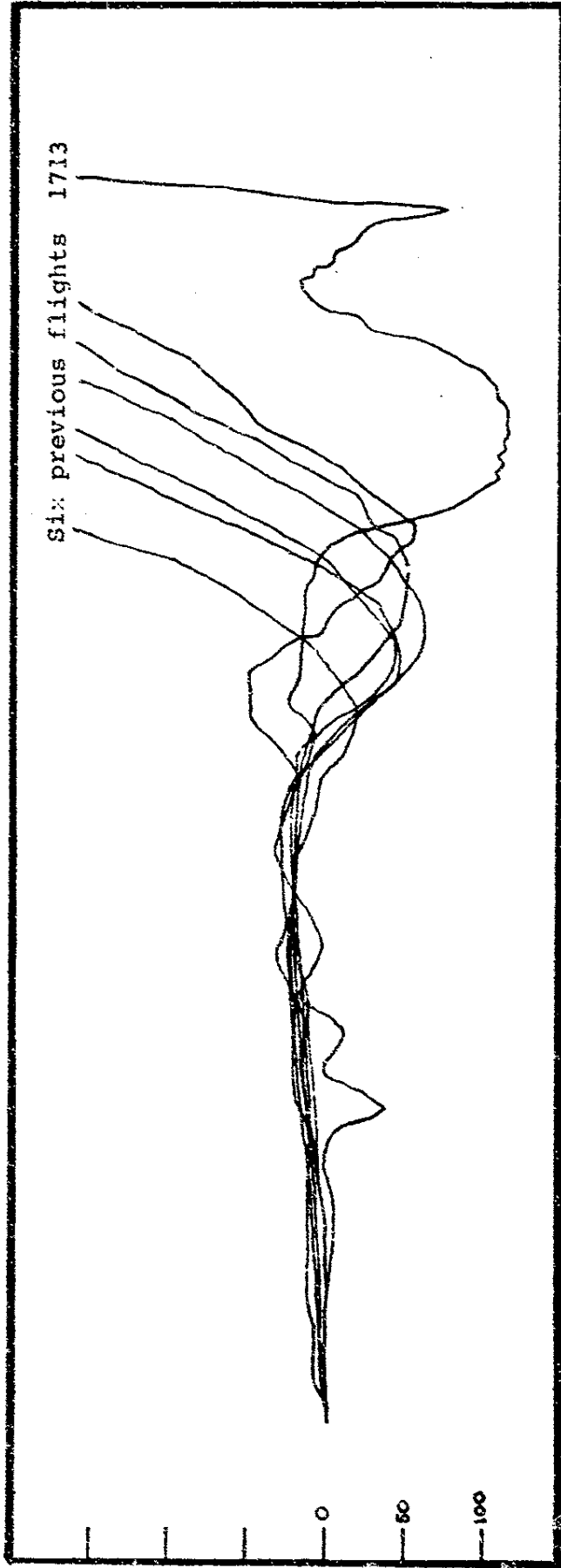

Note: Altitude traces originate at point where corresponding airspeed traces begin to rise.

## APPENDIX F

### CFR AND MEDICAL CONCERNS

Interviews and testimony taken at the public hearing resulting from this investigation revealed shortcomings during the crash/fire/rescue effort in the areas of incident command and control, communications, extrication, proper tools and equipment, rescue personnel training, and medical activity.

#### Incident Command and Control

Lieutenant Ryan, City and County of Denver Fire Department, was notified of the accident at approximately 1417. Lt. Ryan was in command of pumper 25 and was in the first off-airport structural fire truck to arrive on scene. However, before he could enter airport property, he had to stop his vehicle and offload one of his firemen to open the unattended electrically operated gate at airport fire station No. 2. Lt. Ryan stated that this took some time, and he estimated that he arrived on scene at 1430. Initially, he did not know who was the on-scene commander. According to him, fire department procedures state that the first truck officer on the scene was to assume command and that the first truck officer who was to be in command was behind him, also waiting to get through the gate and onto the airport. This officer, Lt. Gupton, picked up Lt. Ryan's man who opened the gate and preceded Ryan's truck to the wreckage. Lt. Ryan assumed that Lt. Gupton would have been in charge as the first truck officer on scene. He saw Lt. Gupton's car and saw him set up his command post. At that time, Lt. Ryan said he did not have a need to know who was in charge because of his activities and he did not assume command and according to him rightfully so. He said that he could have assumed command, but there was too much to do. Given the same conditions again, Lt. Ryan stated he would have assumed command immediately upon his arrival and would have detached himself from any direct rescue efforts until such time as appropriate help arrived.

Assistant Chief Eldon Buller of the City and County of Denver Fire Department was notified of the crash around 1420 via personal pager. He responded to the scene because he was responsible for controlling hazardous materials accidents. He arrived within 15-20 minutes of the accident. Other Denver Fire Department personnel of equal rank were also on scene. Five minutes after Buller's arrival, Chief Gonzales, the chief of the Denver Fire Department called him and put him in command of the rescue effort. Chief Buller attempted to use the airport command post vehicle as a center of operations, but it was full of injured passengers and had a malfunctioning radio. Chief Gonzales then ordered the City of Denver Hazardous Materials vehicle to the scene because it was also equipped to act as a command post. Chief Buller used this vehicle until Division Chief Gerwig took over command about 15 minutes after Buller had initially taken command.

Three airport CFR firefighters stated that Captain Lucas from the airport CFR unit was initially in command of the rescue effort. Two of the airport firefighters stated that Chief Sloss (Airport Chief, CFR stations Nos. 1 and 2) would then assume ultimate control upon his arrival. The third airport fireman stated that City and County of Denver District Fire Chief Starns would be in command upon his arrival at the scene.

No staging areas were established for arriving rescue vehicles. One firefighter stated that an initial attempt was made to stage incoming rescue vehicles, but that it could not be maintained. Several other firefighters did not recall any staging areas for rescue vehicles. The incident commander of triage stated that ambulances were staged at airport station No. 2 and were sent from there to the scene as needed.

According to several rescue workers, as off-airport rescue units began arriving, the crash site became overcrowded with too many rescue personnel. One firefighter stated that rescue personnel were 10 deep in certain areas and waiting to get in to help. He went on to say that if a firefighter gave up his work place "he would have had to go to the end of the line." Many times, it was difficult to get an 18-inch-wide backboard out of the airplane because of the number of people involved.

### Communications

Portable radio communications were not possible between CFR units operating around the airplane due to the noise generated by three large heaters, power units for four hydraulic jaws, three to four portable auxiliary lighting rigs, and fire department portable lighting rigs. Rescue trucks and cranes were also left with their engines running which added to the noise. Problems arose due to this lack of communication because the on-scene commander had to walk around to each of his sector commanders and personally ask them what support or equipment was needed next. Communication between the triage area in CFR station No 2 and the accident scene was also not good. The incident triage commander attempted to use a handheld portable radio, but he could not communicate with medical personnel at the crash site.

### Extrication

The inverted attitude of part of the fuselage and extensive damage to the entire airplane presented rescuers with several problems. The fuselage was crushed downward in the root area of both wings. Live passengers and fatalities in these areas were mixed with snow, dirt, and airplane debris. The left wing was destroyed and the right wing, which was full of fuel, was still attached to the aircraft, which presented a problem in stabilizing the fuselage. Firefighters were very cautious because whatever extrication work (cutting metal, moving the right wing, moving debris, etc.) they performed on one side of the fuselage affected the stability of the entire fuselage section and the safety of passengers who were trapped on the other side of the fuselage. Rescuers found passengers strapped in their seats upside down and deceased passenger were among the survivors, sometimes inches away from each other. There was limited room to work. One fire chief described conditions as "like working in a mine shaft." Great care had to be exercised by rescuers in using extrication tools, such as hydraulic jaws (Hurst tools), so that living passengers and firefighters were not injured. At the rear of the airplane, rescuers worked through the rear cabin escape hatch exit opening. Inside this tailcone exit, for the first 10 feet forward, firemen could stand up; headroom then diminished dramatically toward the front of the plane "like a funnel." The initial impact and the weight of the wing and its fuel load had crushed that portion of the fuselage down to about 2 feet high. Tunneling efforts were undertaken on the left and right sides of the fuselage in an attempt to free passengers. At one point, the fuselage sank down 2 inches. This concerned rescuers because of the crushing danger to passengers and firemen inside the airplane. In addition to these problems, the ambient temperature at the airport was 28° F with moderate snow and fog during rescue operations. Winds at the time were about 10 knots with gusts, at times, up to 17 knots.

### Tools and Equipment

Firemen stated that the Hurst tool was very effective, especially when it was used with a cutter attachment. Also, the Kinman tool (an electrically powered extrication device) was very useful inside the airplane because of its light weight. Airport CFR units had only one available Hurst tool, so off-airport fire department\* vehicles were called in to deliver additional Hurst tools and other extrication equipment. One tool that was found to be very useful was a pair of surgical scissors that was the personal property of one of the firemen. The scissors were useful in cramped working conditions to cut plastic, aluminum sheet, wires, upholstery, and seat belts. Also, knives were useful at the crash site, but in short supply. One maintenance worker gave his knife to a fireman.



Wooden cribbing used during rescue operations consisted of 4- by 4- by 18-inch or 24-inch long blocks, which were carried by CFR vehicles and were used to support parts of the airplane structure, rescue vehicles, etc., during extrication. In this accident, cribbing was used to stabilize the right wing and in the tunneling efforts under the fuselage. A need for large quantities of cribbing existed at the accident site. The size of the cribbing was found to be too small because, as one fireman stated, "it took forever" to build up support piers under the right wing. Firefighters agreed that larger sizes were needed, such as 6- by 6-inch, 8- by 8-inch, or 10- by 10-inch. They also recommended that the cribbing should be made of oak and not fir, to better withstand crushing or compression.

The airplane was eventually lifted by placing the slings of two large cranes around the left and right main landing gear and placing a large forklift truck underneath the right wing. Cribbing was placed on the forklift and it lifted the right wing at the same rate as the two cranes. The cranes had to be brought in from outside the airport several hours after the crash. One firefighter commented that it would have been helpful to have had the cranes available shortly after the crash so the wreckage could have been stabilized sooner. Airport maintenance personnel stated that much of the equipment available at the airport was not used. Their supervisor stated that a study should be made to learn how to effectively utilize this equipment. He also commented that he had never worked with an airframe that was upside down.

Inflatable airbags also were used to separate metal and to lift debris off passengers. One fireman noted that a variety of sizes of airbags would have been useful. One problem was that the airbag could not be used on top of the snow. Consequently, the firefighters had to dig through the snow to solid ground before the bags could be used.

Blankets and stretchers were also in short supply. Snowplow drivers, among the first to arrive on scene, placed ambulatory passengers in the cabs of the snowplows to keep them warm. Other passengers were covered with the drivers' coats and wet passenger coats found lying around the wreckage. One driver cut the tailcone emergency escape slide and used it to cover a passenger. Maintenance personnel also carried injured passengers to fire rescue vehicles that were already on the scene because there were no stretchers immediately available. One snowplow driver stated that stretchers and backboards started to arrive 20-25 minutes after he got to the wreckage, after all the passengers that had been found on the ground had been picked up and placed in various vehicles at the scene. He closed by saying that if blankets and backboards had been prepositioned in the snowplows, the plow drivers could have helped the passengers sooner.

### Rescue Training

One firefighter stated that it was difficult to work inside the inverted portion of the fuselage. He could recall no training exercises involving an upside-down airplane. Firemen stated that they have had considerable training extinguishing fires in old airplane hulks, in the operation of emergency escape slides, and involving collapsed landing gear. However, there had been no training on the best locations to cut into a fuselage, where the stronger metals and sections are located, or where the fuel and hydraulic lines are located. One firefighter stated that firemen had used tools to cut into several old aircraft hulks on the airport, but not on newer and larger aircraft. Another stated, "newer model aircraft fuselages are hard to come by." Their training emphasis had been more on fire suppression rather than extrication.

At one point, Chief Buller had an empty fuel truck along with airport maintenance personnel brought to the site to attempt to defuel the right wing. He eventually decided against the defueling because nobody was able to give him precise instructions as to how it should be done. He stated that he did not want a fuel spill that may have caught fire.

### Medical Concerns

Dr. Brunko, the on-scene medical coordinator for this accident and a witness at the Safety Board's public hearing, indicated that the overall medical response to the crash was well-conducted. He did, however, indicate several problem areas.

The triage tags used to indicate injury severity could not be used because of the cold weather. The strings used to attach the tags to injured people became entangled and frozen together, rendering the tags unusable. Consequently, only five or six injured people received triage tags. Also, the pens used to write on the tags malfunctioned due to the frozen ink.

Due to the small space available within the fuselage of the airplane, all treatment of injuries took place after the injured were extricated from the wreckage. In addition, treatment was affected because the medical personnel arrived on scene without proper cold weather clothing.

Dr. Brunko also expressed concern because his medical workers had communication problems similar to other rescue workers due to the noise and malfunctioning handheld radios. He also stated that there was a delay in transporting injured to one hospital because the bus they were placed in became stuck in the mud, necessitating their transfer to another bus. Lastly, he too, believed that the presence of Continental employees at the accident site hampered triage efforts.

